

RUNGU® JUGGERNAUT OWNERS MANUAL

Congratulations on purchasing the Juggernaut¹! Before you ride and make new tracks, *please read the following instructions carefully.*



IMPORTANT- Standard Bearer Machines will not be liable for any damage or injury that may occur due to operation of our trikes. By using the Juggernaut, you are agreeing to Standard Bearer Machines Terms and Conditions and the warnings and conditions of the Generic Bike Manual which are included with other files in the USB key accompanying the Juggernaut.

¹ As the owner, you agree and are bound by all sales and transfer conditions as defined in “SBM Rungu Sales Terms and Conditions US 2017a” or “SBM Rungu Sales Terms and Conditions US 2017 – Demo Model.” Copies of these documents are available on the USB drive that ships with the product or upon request by e-mailing sales@riderungu.com.

Contents

| | |
|---|----|
| Parts identification | 3 |
| Unpacking and Assembly Instructions | 5 |
| Tools required | 5 |
| Unpacking and Assembly Instructions | 6 |
| Cautions and Safety | 14 |
| General Cautions and Warnings | 14 |
| Riding the Juggernaut | 15 |
| Juggernaut Operation Cautions | 15 |
| Using the Optional Front Suspension | 16 |
| Using the parking brake switch..... | 16 |
| Riding Safety | 17 |
| Tire pressure | 17 |
| Getting more information..... | 17 |

Parts identification

The following images show the names of various components on the Juggernaut





Figure 2 - Handlebar top view Kilimanjaro pre-2017



Figure 3 2017 front brake

Unpacking and Assembly Instructions

Warning: Failure to follow instructions may lead to incomplete or faulty assembly that can result in accidental rider injury or death.

Before you ride and make new tracks, please follow the assembly instructions carefully. The team at Standard Bearer Machines recommends that you have the assembly performed by a qualified bike mechanic.

Tools required

- 5mm Hex wrench
- 6mm Hex wrench
- Tire inflation pump (presta valve)
- Wire cutters or scissors to remove packing material

Unpacking and Assembly Instructions

Warning: Failure to follow these instructions may lead to incomplete or faulty assembly that can result in accidental rider injury or death.

1. The trike comes in a cardboard carton. After you have removed the binding straps and tape from the top cover, remove the top cover on the front of the trike. If you intend to ship or return the trike, please keep all packing materials.
2. Remove the accessory box containing Quick Release Skewers, tools, USB document drive and pedals.



Accessory Box. May be located elsewhere inside the carton

3. Lift the frame and attached components from the carton.



CAUTION: THE JUGGERNAUT WEIGHS 50 LBS (23 KG) USE TWO (2) PEOPLE TO REMOVE THE TRIKE FROM THE PACKAGING TO AVOID INJURY

4. Disconnect the front wheels from the frame packaging and remove the protective packaging from the forks.
5. Open the accessory box to remove the two quick release skewers from the packaging.
6. Select which wheel will be the right-side wheel and the left-side wheel. Unscrew the retention nut from one of the quick-release skewers and insert the skewer into the left wheel from the side of the brake disc as shown below.



7. Replace the retention nut as shown below.



9. Mount the wheel to the left fork as shown in the two pictures below. For the Juggernaut, insert the wheel into the fork at an angle to clear the tire width as pictured.



10. Tighten and close the quick-release once the wheel is mounted in the fork.

Warning: make sure to tighten the quick-release in the fork so that it cannot fall out of the fork; failure to adequately tighten the quick-release can result in accidental rider injury or death.

11. Place the trike aside while performing the next two assembly steps.
12. Unscrew the retention nut from one of the quick-release skewers and insert the skewer into the right wheel from the side opposite to the brake disc, as shown below.



13. Replace the retention nut.



14. Mount the wheel to the right fork.
15. Tighten and close the quick-release once the wheel is mounted in the fork.

Warning: make sure to tighten the quick-release in the fork so that it cannot fall out of the fork; failure to adequately tighten the quick-release can result in accidental rider injury or death.

16. On a level surface, stand the trike upright and remove the packaging from the front steering assembly, then remove the handlebars from the frame and packaging.
17. Use the 5mm hex wrench to loosen the handlebar retention screws as shown below



18. Insert the right and left handlebars into the stems. Rotate the handlebars vertically to ensure the best fit for you.
19. FOR STANDARD (NON SUSPENSION) FORKS: When you have found the best fit for each handlebar, ensure that the inside end of each handlebar extends up to 30mm as depicted below and then tighten all four retention screws. Use a pattern of tightening the upper screw and then bottom screw instead of tightening both top screws and then the bottom screws.



20. FOR OPTIONAL SUSPENSION FORKS: When you have found the best fit for each handlebar, ensure that the inside end of each handlebar extends up to **45 mm** as depicted below and then tighten all four retention screws. Use a pattern of tightening the upper screw and then bottom screw instead of tightening both top screws and then the bottom screws.

21. Use the pattern shown below to tighten the handlebar clamp screws.

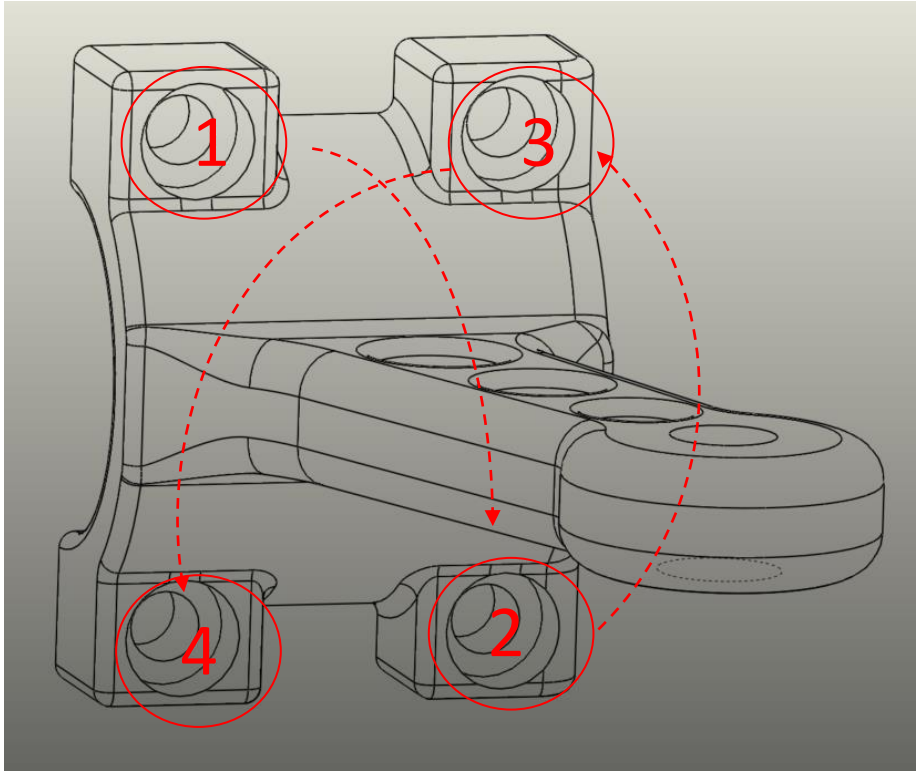

Warning: Tightening handlebar clamp bolts beyond 6Nm (53 in lbs.) or failing to align the bolts with the threads in the stem may strip threads in stem leading to insufficient tightening of the handlebar. Failure to tighten handlebar sufficiently may result in unexpected handlebar rotation that can result in accidental rider injury or death.

22. Remove the remainder of the packing materials.

24. Install the left pedal first – the left pedal is marked with an “L” as shown below.



25. The left pedal is threaded backwards, so thread the shaft into the crank arm in a counterclockwise motion as depicted below.

Caution: Do not force the threading of the pedal onto the crankset. Warranty does not cover replacement cranks for stripped threads.



26. Use a 6mm Hex wrench to tighten the pedal.



27. Install the right pedal and finger tighten the pedal clockwise – the right pedal is marked with an “R” as shown below.

Caution: Do not force the threading of the pedal onto the crankset. Warranty does not cover replacement cranks for stripped threads.



28. Use a 6mm Hex wrench to tighten the pedal.
29. Inflate the Fat Tires between 10 and 15 PSI (69 to 104 KPa); inflate the 29 in. (700c) tires between 35 and 55 PSI (241 KPa to 379 KPa) before riding (KILIMANJARO ONLY).

Cautions and Safety

General Cautions and Warnings

The Juggernaut is a tricycle that you can ride like a bicycle with the added benefit of more stability on soft ground.

Refer to the **All Purpose Bicycle Manual** available on the Rungu USB drive that ships with the Juggernaut to new customers or online at this [link](#)².



WARNING: Being a tricycle, the Juggernaut has a tie-rod that connects the two front forks. DO NOT USE the tie-rod to lift the trike. The steering uses the tie rod as a hard stop so the forks don't rub against the front wheels. Grasping the tie rod when lifting WILL RESULT IN A PINCH TO THE HAND AND FINGERS THAT MAY LEAD TO HAND OR FINGER INJURY. ONLY GRASP PARTS OF THE FRAME OR SADDLE TO LIFT THE TRIKE.

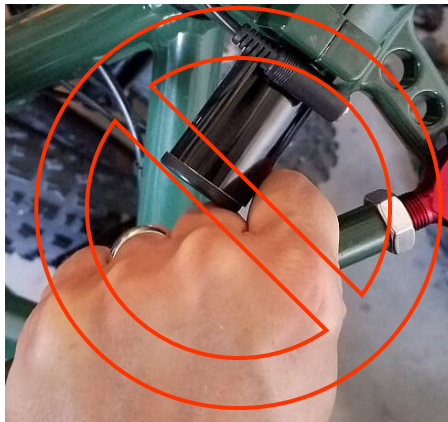
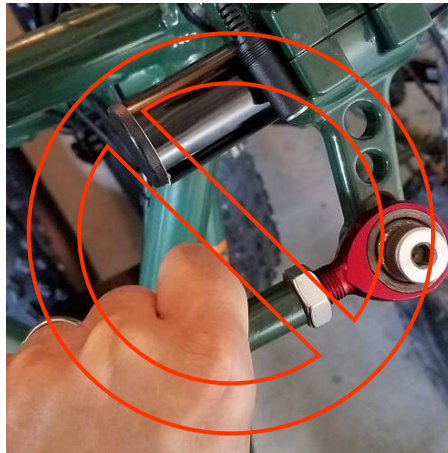

² <http://riderungu.com/riderungu/wp-content/uploads/2016/08/Generic-Bike-Manual.pdf>

Riding the Juggernaut

NOTE: Refer to Rungu Juggernaut Best Practices (on your USB drive and online) for more information on how to get the best experience with the Rungu Juggernaut.

Juggernaut Operation Cautions

1. ***DO NOT apply the brakes abruptly when going downhill as this may result in loss of control. Use consistent, gradual braking.***
2. ***Ride the trike at a level and speed you are comfortable with. Do not push the boundaries of your skill level or the trike!***
3. ***NEVER jump with the Juggernaut. The Juggernaut is designed for moderate bumps but jumping your trike can lead to serious injury and/or damage!***

Using the Optional Front Suspension

The front suspension has two manual controls that can change ride and handling characteristics. Looking from above astride the trike, the right-side knob controls the stiffness of the suspension. The left side switch is used to disable/enable the suspension.



To stiffen or loosen the suspension, turn the right-side knob clockwise or counter-clockwise respectively. All trikes ship with the suspension at the loosest setting. If you find that the front end dives too much, or that you are having difficulty turning on soft ground (sand, snow), increase the stiffness of both forks by turning the knob clockwise.



When activated, the optional front suspension for the Juggernaut smoothens cornering on hard surfaces and improves control on soft sand. Under some circumstances such as when the rear wheel drifts sideways in very soft sand, the suspension may make it difficult to stay upright. Under these circumstances, Rungu recommends disabling the front suspension by turning the switch from the Open position to the Lock position.

Using the parking brake switch

With the 2017 Model, the front or rear hydraulic brake (or both) levers have a parking brake switch. To operate the switch, hold in the brake lever and flip the switch. The switch holds the brake lever in place, which holds the rotor in place and prevents the trike from moving when parked. The parking brake is very useful when parking on angle. REMEMBER to switch off the parking brake before riding.

NOTE: Riding with the parking brake engaged produces significant wear on the brake pads leading to a decrease in brake pad life and stopping power.

Warranty DOES NOT cover replacement brake pads.

Riding Safety

1. ALWAYS wear proper safety equipment
2. NEVER operate at speeds that exceed your ability to operate the trike safely
3. ALWAYS know your surrounding and actively scan the terrain for obstacles
4. DO NOT wear loose fitting clothes or articles
5. NEVER ride with more than 1 rider
6. Know your trike and personal limits

WARNING: DO NOT RIDE AT NIGHT WITHOUT APPROPRIATE REFLECTORS AND LIGHTING. STANDARD BEARER MACHINES, LLC DOES NOT SHIP THE TRIKE WITH ANY COMPONENTS FOR NIGHT-TIME RIDING SAFETY. IT IS THE OWNER'S RESPONSIBILITY TO EQUIP THE TRIKE WITH APPROPRIATE REFLECTORS AND LIGHTING TO RIDE SAFETY AT NIGHT.

WARNING: IF ANY INJURIES OR HARM OCCUR WHEN YOU USE THE PRODUCT, THE MANUFACTURER OR DISTRIBUTOR WILL NOT BEAR ANY RESPONSIBILITY

Tire pressure

Check the pressure in your tires. The required pressure can be found on the sidewall of the tire. Normal pressure is 10 PSI. Though the tires perform better in sand and deep snow at lower pressures, pressures may cause sidewalls to collapse, and that is how most blowouts occur.

NOTE: Standard Bearer Machines are NOT RESPONSIBLE FOR FLAT TIRES!

Getting more information

Thank you again for purchasing a Rungu Trike. For further questions, please consult the [Technical Documentation page](#) on the riderungu.com website.