

RUNGU® ELECTRIC JUGGERNAUT (MID-DRIVE MODELS) OWNER MANUAL

Congratulations on purchasing a Rungu Electric Juggernaut¹! You own the latest generation of the ultimate electric alternative to a Quad ATV for on-road and off-road fun. Before you ride and make new tracks, *please read the following instructions carefully.*

Standard Bearer Machines, LLC (Standard Bearer Machines) thanks you for your purchase!

Electric Juggernaut uses the Bafang BBSHD mid-drive motor with a custom Rungu 52V (nominal voltage) input that generates more than 1.4kW of mechanical power for off-road use. You access the power by pedaling (“Pedelec”) or pressing the thumb throttle. As a “Pedelec,” the Electric Juggernaut senses when you start to pedal and engages the motor to assist your pedaling - you don’t have to use the throttle if you don’t want to. The amount of power assist varies based on the power level you select as you ride. The Electric Juggernaut has five selectable power levels starting with barely any assist up to full power, which is intended for use off-road only. The power settings are discussed below.

Note: US Federal Law mandates a 750W/20 MPH limit for riding an e-bike on public roads without a license. Please check with your local government to ensure you follow all local laws and ordinances. Standard Bearer Machines are not liable for those who choose not to follow their local laws.

CAUTION: STANDARD BEARER MACHINES WILL NOT BE HELD RESPONSIBLE FOR PEOPLE WHO CHOOSE TO DISREGARD THE LAW!

WARNING: IMPORTANT- STANDARD BEARER MACHINES WILL NOT BE LIABLE FOR ANY DAMAGE OR INJURY THAT MAY OCCUR DUE TO OPERATION OF YOUR ELECTRIC JUGGERNAUT. BY USING THE ELECTRIC JUGGERNAUT, YOU ARE AGREEING TO STANDARD BEARER MACHINES TERMS AND CONDITIONS AND THE WARNINGS AND CONDITIONS OF THE GENERIC BIKE MANUAL WHICH ARE INCLUDED WITH OTHER FILES IN THE USB KEY ACCOMPANYING THE ELECTRIC JUGGERNAUT.

¹ As the owner, you agree and are bound by all sales and transfer conditions as defined in “SBM Rungu Sales Terms and Conditions US 2019.” Copies of these documents are available on the USB document drive that ships with the product or upon request by e-mailing sales@riderungu.com.

Contents

Electric Juggernaut parts identification	4
Unpacking and Assembly Instructions	6
Tools required	6
Unpacking and Assembly Instructions	7
Additional Installation Instructions – mud flaps	28
Additional Installation Instructions – Rungu Cargo Rack with or without range-extending battery.	32
Cautions and Safety	40
General Cautions and Warnings	40
Battery Safety.....	41
Battery Safety Precautions.....	42
Catastrophic Battery Failure	42
Battery Safety (In Depth)	43
Battery Failure Response Procedure	44
Operating Electric Juggernaut.....	45
Charging Your Main Battery – Single battery units (Standard, HC+)	45
Charging Dual Batteries – Dual Battery Units (Overland, Rubicon).....	53
Before your first ride – Safety Check	59
Using the control keypad and understanding the dashboard	62
Turning on Electric Juggernaut	62
Reading the dashboard	62
Accessing the display settings.....	64
Toggling the (optional) Rungu E-Light on and off	64
Turning off Electric Juggernaut	64
Built-in USB charging port.....	65
PIN Code.....	65
Push assistance	65
Riding Electric Juggernaut.....	66
Riding Electric Juggernaut, the first time	66
Using Gear Shifters.....	66
Understanding and changing Electric Juggernaut Power Level	67
Power level and gear combination guidelines	70

Electric Juggernaut Operation Cautions	70
Riding Safety	71
Adjusting the Front Suspension	72
Using the parking brake switch.....	72
Using the optional 12VDC outlet	73
Rungu Electric Juggernaut Maintenance and Care	74
Before Each Ride	74
After Each Ride.....	74
Battery Care	74
Storage When Not Using Electric Juggernaut for Periods of Two Weeks or Longer	74
Prolonging the Life of your Battery – Best Practices	75
Maintenance – After strenuous rides, and every 500 miles or six months	75
Securing your Electric Juggernaut.....	76
Rear wheel removal or replacement	76
How to remove the rear wheel.....	77
How to replace the rear wheel	83
Wheel speed sensor alignment	88
Technical Information	92
Default Display Settings	92
Dimensions.....	92
Performance	93
Electrical.....	93
Troubleshooting.....	94
Electrical.....	94
Motor and System Performance.....	95
Mechanical.....	96
Getting more information.....	97

Electric Juggernaut parts identification

The following images show the names of various components on the Electric Juggernaut



Figure 1 Left Side View



Figure 2 Right Side View

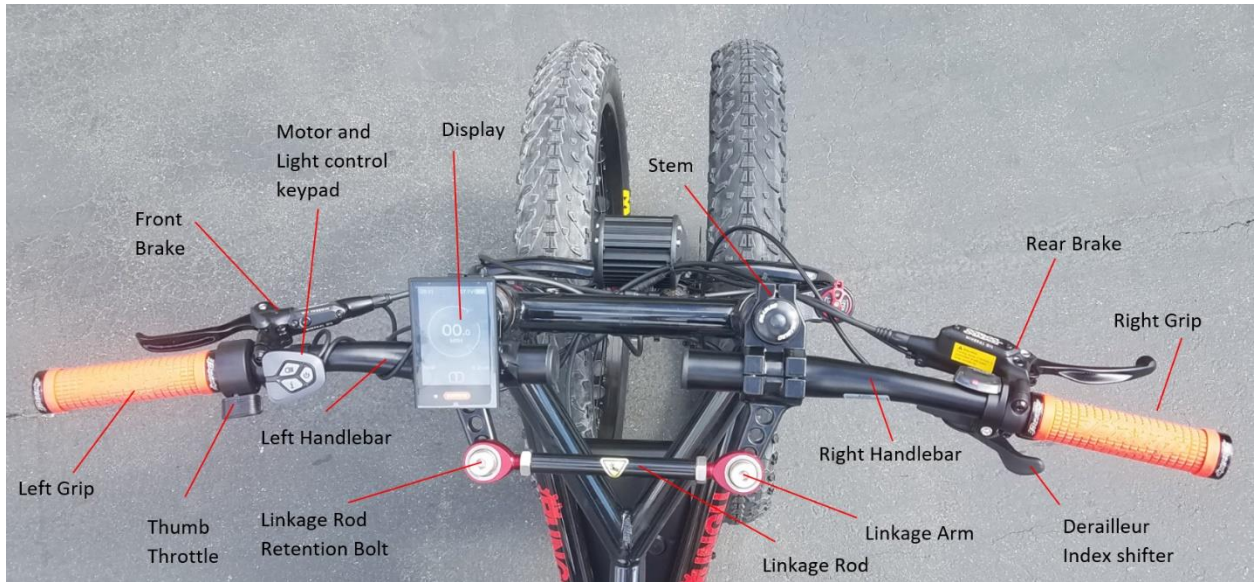

Figure 3 Steering assembly view

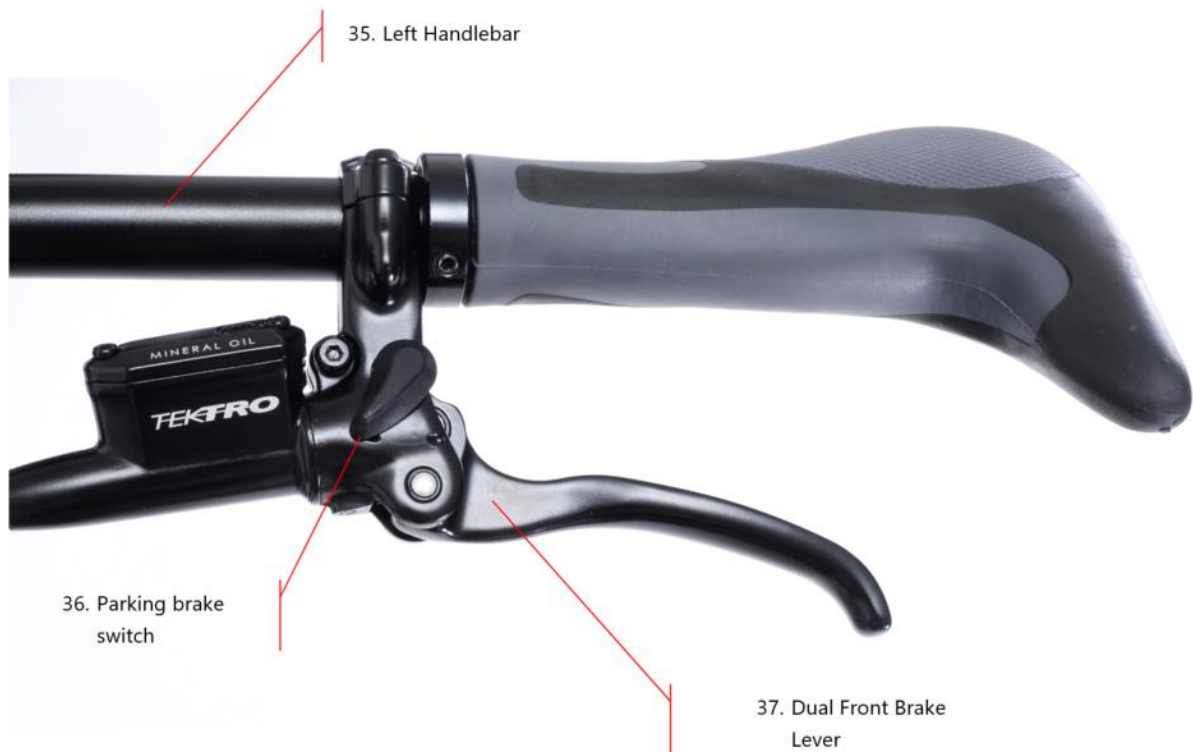

Figure 4 Parking Brake View

Unpacking and Assembly Instructions

WARNING: FAILURE TO FOLLOW INSTRUCTIONS MAY LEAD TO INCOMPLETE OR FAULTY ASSEMBLY THAT CAN RESULT IN ACCIDENTAL RIDER INJURY OR DEATH.

Before you ride and make new tracks, please follow the assembly instructions carefully. The team at Standard Bearer Machines recommends that you have the assembly performed by a qualified bike mechanic.

Tools required

- 5mm Hex wrench
- 6mm Hex wrench
- Adjustable wrench
- Tire inflation pump (presta valve)
- Bicycle Tire pressure gauge – presta valve
- Wire cutters or scissors to remove packing material

Unpacking and Assembly Instructions

WARNING: FAILURE TO FOLLOW THESE INSTRUCTIONS MAY LEAD TO INCOMPLETE OR FAULTY ASSEMBLY THAT CAN RESULT IN ACCIDENTAL RIDER INJURY OR DEATH. IF YOU ARE NOT COMFORTABLE PERFORMING THE STEPS BELOW, HAVE A PROFESSIONAL BICYCLE TECHNICIAN ASSEMBLE YOUR ELECTRIC JUGGERNAUT.

1. Electric Juggernaut comes in a cardboard carton. After you have removed the binding straps, remove the top cover. If you intend to ship or return your Rungu, please keep all packing materials.
2. If you have purchased a model with a Rungu Cargo Rack (HC+, Overland, Rubicon Trail Edition) or an optional Cargo Rack, remove the rack and place it to one side.
3. Remove the accessory box containing Quick Release Skewers, AC battery charger, tools, USB document drive, keys and pedals.

Note: If you purchased an Electric Juggernaut with dual batteries or with the optional Cargo Rack, remove the rack first and place it to the side.



Accessory Box. May be located elsewhere inside the carton

4. Remove the two wheels from the carton and place them aside carefully to avoid damaging the disc brake rotors.

5. Lift the frame and rear wheel from the carton and place the assembly on the floor gently so that it stands upright as it was in the carton.

CAUTION: ELECTRIC JUGGERNAUT FRAME AND REAR WHEEL WEIGH 68 LBS (31 KG). USE TWO (2) PEOPLE TO REMOVE THE ELECTRIC JUGGERNAUT FROM THE PACKAGING TO AVOID INJURY

6. Remove the packaging from the front forks steering assembly and handlebars.
7. Use the 5mm hex wrench to loosen the handlebar retention screws as shown below



8. Slide the right handlebar into the handle bar clamp.



9. Insert the handlebar so that it extends at least 45 mm or 1 ¾" past the inside of the stem.



10. Fasten, but do not tighten handlebar retention screws



11. Remove the left handlebar retention screws allowing the left-side linkage arm to move away from the stem



12. Place the left-side handle bar such that the display support bridges the stem. Take care to make sure the display and control cables are behind the stem as shown below.



13. Then replace the left-side linkage arm and the handlebar retention screws. Fasten but do not tighten the handlebar retention screws.



14. Ensure that the left handlebar extends at least 45 mm or 1 3/4" past the stem.



15. Tighten both sets of handlebar retention screws so that you can still rotate each handlebar and slide the handlebar inside the stem.
16. Rotate the handlebars so that each side aligns, and they fit best for you.

Note: For additional adjustments after your first ride, loosen the handlebar retention screws and then repeat steps 16 and 17.

17. When you have aligned each handlebar, use a pattern of tightening the upper handlebar retention screw and then bottom screw instead of tightening both top screws and then the bottom screws.

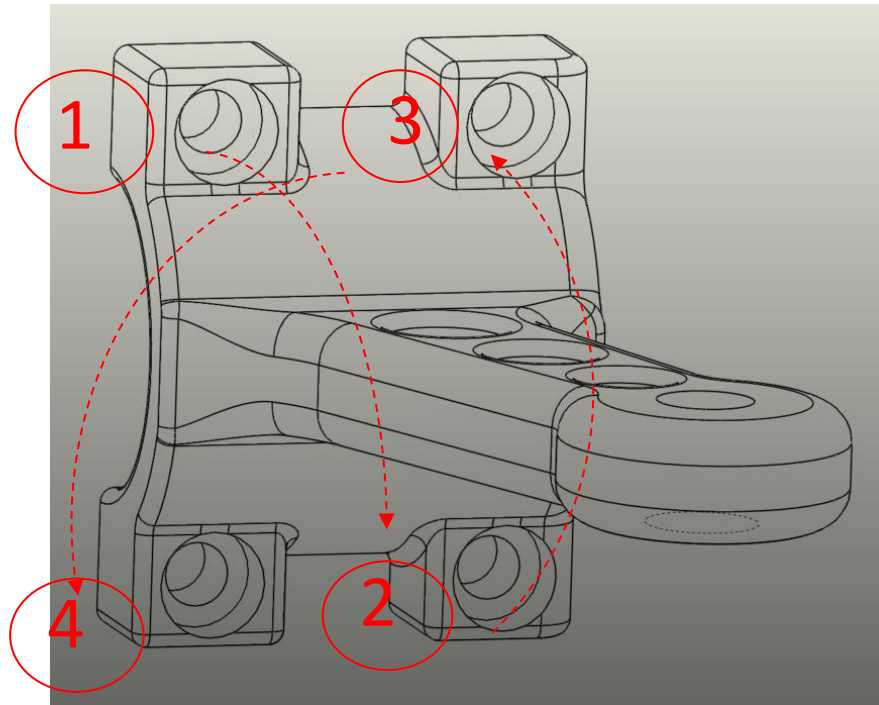

WARNING: TIGHTENING HANDLEBAR RETENTION SCREWS BEYOND 6NM (53 IN LBS.) OR FAILING TO ALIGN THE SCREWS WITH THE THREADS IN THE STEM MAY STRIP THREADS IN STEM LEADING TO INSUFFICIENT TIGHTENING OF THE HANDLEBAR. FAILURE TO TIGHTEN HANDLEBAR SUFFICIENTLY MAY RESULT IN UNEXPECTED HANDLEBAR ROTATION THAT CAN RESULT IN ACCIDENTAL RIDER INJURY OR DEATH.

18. Open the accessory box to remove the two quick release skewers from the packaging.
19. Select which wheel will be the right-side wheel and the left-side wheel. Often, the wheels will be labeled “L” or “R”. This means that the brakes have been adjusted differently for each wheel – use the labels to guide which wheel mounts on which side.

Note: The left side is considered the side with the brake rotors. The right side has the chain and gearing.

20. Mount the left wheel to the left fork as shown in the two pictures below. Be careful to slide the brake rotor between the disc caliper.



21. Mount the right front wheel to the right fork. As with the left wheel, make sure that the brake rotor slides between the brake calipers.



22. Unscrew the retention nut from one of the quick-release skewers and remove the associated conical spring.



23. Insert the skewer into the left wheel from the side of the brake disc as shown below.



24. Replace the retention nut and conical spring as shown below.



25. Make sure that the quick release retention nut and lever are seated in the fork dropouts.



26. Tighten the retention nut and close the quick-release lever once the wheel is mounted in the fork. As a guideline the retention nut should begin to clamp when the lever points away from the wheel at a right angle.



WARNING: MAKE SURE TO TIGHTEN THE QUICK-RELEASE IN THE FORK SO THAT IT CANNOT FALL OUT OF THE FORK; FAILURE TO ADEQUATELY TIGHTEN THE QUICK-RELEASE CAN RESULT IN ACCIDENTAL RIDER INJURY OR DEATH.

27. Unscrew the retention nut from the other of the quick-release skewers and remove the associated conical spring.
28. Insert the skewer into the right wheel from the outside as shown.



29. Replace the retention nut and conical spring as shown below.



30. Make sure that the quick release retention nut and lever are seated in the fork dropouts.



31. Tighten the retention nut and close the quick-release lever once the wheel is mounted in the fork. As a guideline the retention nut should begin to clamp when the lever points away from the wheel at a right angle.



WARNING: MAKE SURE TO TIGHTEN THE QUICK-RELEASE IN THE FORK SO THAT IT CANNOT FALL OUT OF THE FORK; FAILURE TO ADEQUATELY TIGHTEN THE QUICK-RELEASE CAN RESULT IN ACCIDENTAL RIDER INJURY OR DEATH.

32. Remove the pedals from the box and install the left pedal first – the left pedal is marked with an “L” as shown below.



33. Use your fingers to thread the pedal shaft into the crank arm in a counterclockwise motion – the pedal uses a left-hand thread. For best results, hold the threaded section of the pedal in the crank arm mounting hole and spin the entire crank arm in a clockwise motion as depicted below.

Caution: Do not force the threading of the pedal onto the crankset. Warranty does not cover replacement cranks for stripped threads.



26. Use a 6mm Hex wrench to tighten the pedal.



34. Use your fingers to thread the right-side pedal shaft into the right-side crank arm in a clockwise motion. For best results, hold the threaded section of the pedal in the crank arm mounting hole and spin the entire crank arm in a counterclockwise motion as depicted below.

CAUTION: DO NOT FORCE THE THREADING OF THE PEDAL ONTO THE CRANKSET. WARRANTY DOES NOT COVER REPLACEMENT CRANKS FOR STRIPPED THREADS.



27. Use a 6mm Hex wrench to tighten the pedal.



28. Inflate the Fat Tires between 5 and 10 PSI (34 to 69 KPa)

Note: Tire pressure plays a very important role in how you enjoy your Rungu Electric Juggernaut. If you plan to ride mostly on soft ground like sand or snow, use a tire pressure between 5 (34 kPa) and 6 PSI (41 kPa) for best traction and control as well as minimizing tread wear. Use 10 PSI (69 kPa) if you plan to ride on harder surfaces like rock or dirt road. On harder surfaces, a higher pressure minimizes tread wear and improves the range of your Electric Juggernaut.

CAUTION: AVOID UNDERINFLATING AND OVER INFLATING THE TIRES. UNDER INFLATION (BELOW 5 PSI) WILL PREVENT THE TIRE FROM SEATING ON THE TIRE AND PREVENT YOU FROM RIDING ELECTRIC JUGGERNAUT. OVER INFLATION (MORE THAN 15 PSI – 103 KPA) MAY RESULT IN TIRE BLOW-OUT WHILE RIDING.

29. Loosen the Seat Post Clamp by opening the lever. Insert the seat post and adjust to the height that suits you, then tighten the clamp by closing the lever.

Note: Failure to tighten the seat post can result in discomfort while riding Electric Juggernaut.

WARNING: DO NOT EXTEND THE SEAT POST BEYOND THE MAXIMUM HEIGHT LIMIT BEFORE CLAMPING. THIS CAN RESULT IN THE SEAT POST BREAKING AND RESULTING IN SEVERE INJURY OR DEATH.

30. If the model you purchased includes optional mud flaps (HC+, Overland, Rubicon) or the Rungu Cargo Rack with the range-extending battery, continue to the additional instructions for installation. If you have purchased (or you also have the) the Rungu Cargo Rack, please refer to the Rungu Cargo Rack installation instructions for assembly.
31. Before riding, refer to the section [Operating Electric Juggernaut](#).

Additional Installation Instructions – mud flaps



1. Remove the mud flaps from packaging along with their screws and retention nuts. Remove the retention nut from each screw.

2. Align the mounting slot on the first mud flap with the back of the front fork. Install the screw from the front of the fork as shown below.



3. Thread the nut onto the back of the screw behind the mounting slot.



4. Use an adjustable wrench to secure the nut.



5. Use a 5mm hex wrench to continue threading the nut onto the screw



6. Before fully tightening the nut, slide the mud flap vertically until the bend in the mud flap rises just above the lip on the back of the fork as shown below.



7. Adjust the mud flap to align it with the tire and fully tighten the nut.
8. Repeat these steps for the second mud flap.

Additional Installation Instructions – Rungu Cargo Rack with or without range-extending battery.



Note: If you have a high bandwidth Internet connection, [click here](#) to watch a video of these installation instructions.

1. First, remove the Cargo Rack from packaging and remove the three M8 retention screws and washers from the top of the rack.



2. Place the rack over the rear tire making sure that the tabs at the bottom of the rack are on the outside of the metal rack supports.



3. Align the holes in the tabs at the bottom of the rack with the fastening locations on the tab, and thread the M8 screws and star washers through the tabs and into the rack supports on both sides. Finger-tighten the two screws.



4. Align the front of the rack with the mounting bracket and place the remaining M8 screw and star washer into through the top mounting bracket hole and into the threaded hole on the front of the rack.



5. Use a 6 mm hex wrench to tighten all three screws, start with the screw on the mounting plate in the front.

CAUTION: IF YOU HAVE THE RUNGU CARGO RACK WITH RANGE-EXTENDING BATTERY AVOID PINCHING THE WIRE HARNESS BETWEEN THE RACK AND THE LEFT SIDE OF THE FRAME.

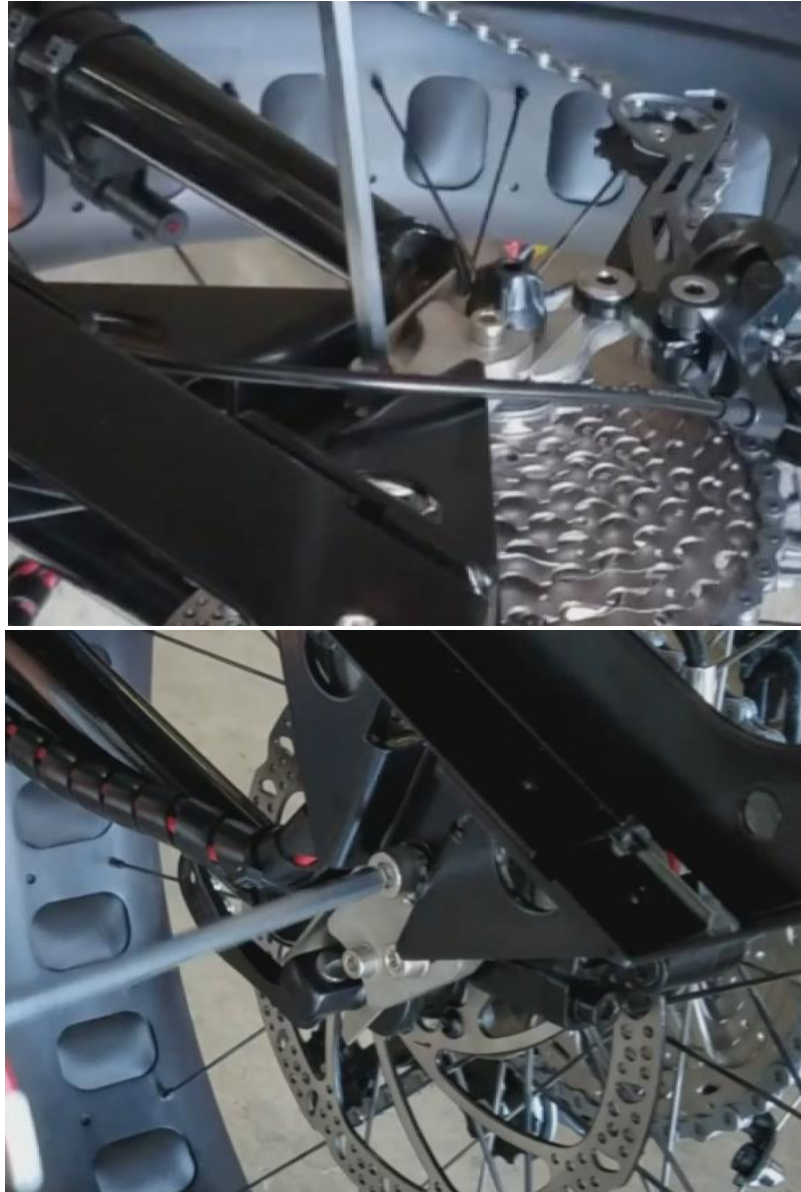

Note: If you have the standard Rungu Cargo Rack, your rack installation is complete. Continue to step 6 if your Rungu Cargo Rack includes the range-extending battery.

6. Use the zip-ties provided to fasten the wire harness to the rack in at least two places. Keep the grommet above the zip-tie locations. Clip and remove the zip-tie tails after you've tightened the zip-ties.

CAUTION: MAKE SURE THE CABLE HARNESS OR THE ZIP-TIES DON'T INTERFERE WITH THE MOTION OF THE REAR WHEEL AND REAR BRAKE.



7. Use the keys provided to open the access door to the rear battery and insert the end of the cable harness into the rear battery compartment through the hole provided in the side of the Cargo Rack.

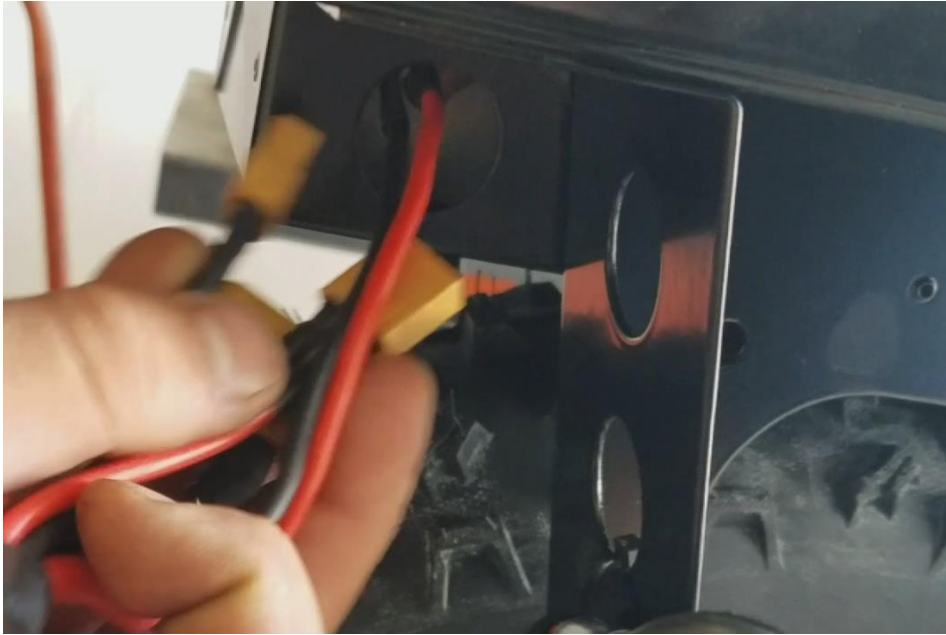

8. Pull the end of the harness into the rear battery compartment so that the connectors are clear of the hole.

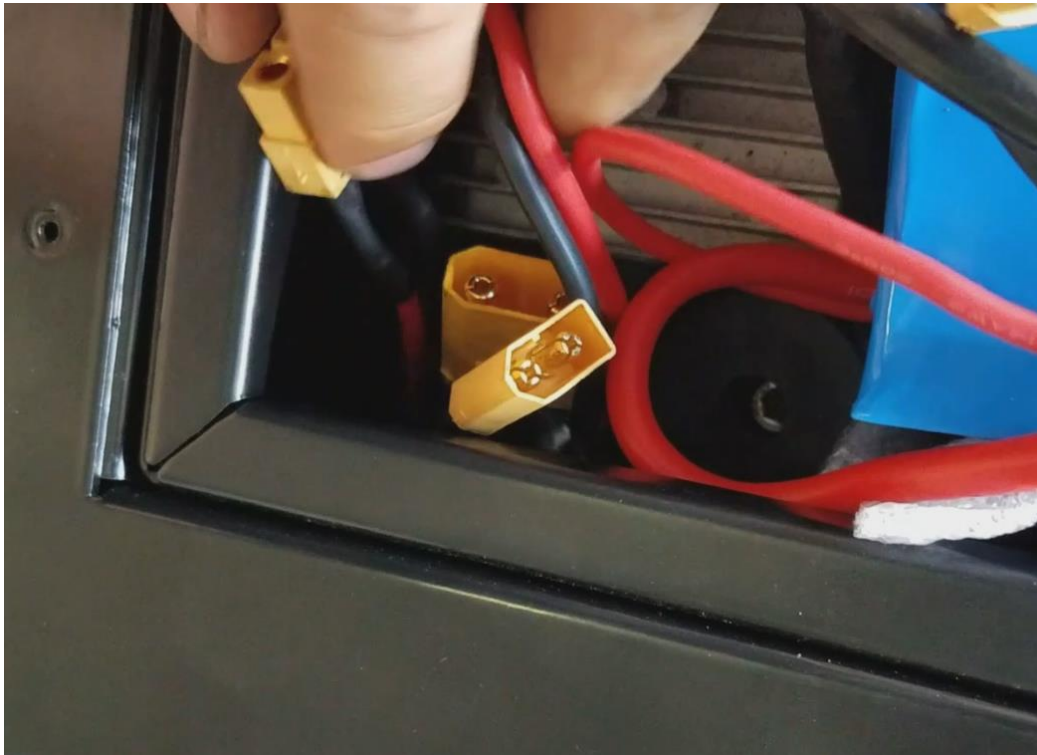

9. From the outside of the rack insert the grommet on the harness so that it covers the entire hole in the battery case and secures the cable harness.



10. There are one or three connections to make inside the battery compartment depending on the model Rungu or options you purchased. First, connect the largest connectors together – this is the connection between the rear battery and the Rungu Battery Link so that the front and rear batteries work together to extend your practical range.

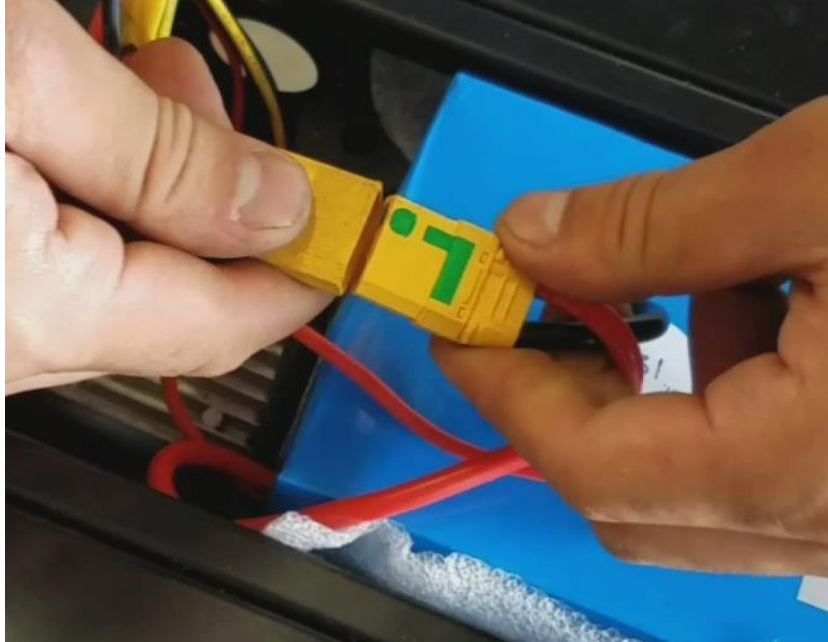

11. If you have the Rungu Rubicon Trail Edition or you have purchased the optional 12VDC power outlet, connect the two color-coded small connectors together.

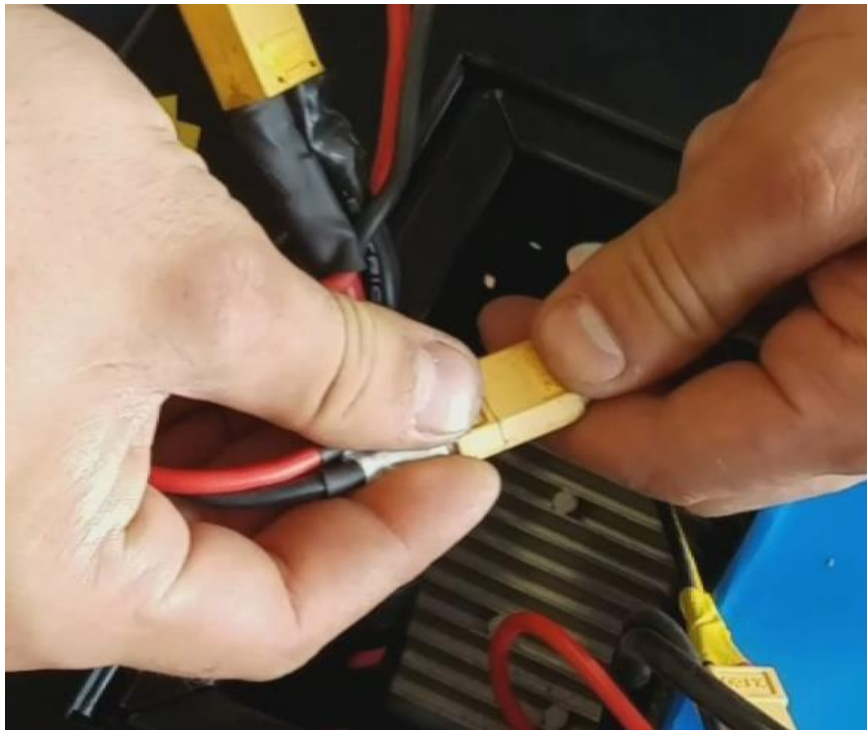

Cautions and Safety

General Cautions and Warnings

The Electric Juggernaut is an electric vehicle that you can ride like a bicycle with the added benefit of more stability on soft ground.

For all bicycle riding cautions and warnings, refer to the **All Purpose Bicycle Manual** available on the Rungu USB document drive that shipped with your Electric Juggernaut. If you cannot find your copy of the All Purpose Bicycle Manual, email support@riderungu.com and request an electronic copy.



WARNING: THE ELECTRIC JUGGERNAUT HAS A TIE-ROD THAT CONNECTS THE TWO FRONT FORKS. DO NOT USE THE TIE-ROD TO LIFT ELECTRIC JUGGERNAUT. THE STEERING USES THE TIE ROD AS A HARD STOP SO THE FORKS DON'T RUB AGAINST THE FRONT WHEELS. GRASPING THE TIE ROD WHEN LIFTING WILL RESULT IN A PINCH TO THE HAND AND FINGERS THAT MAY LEAD TO HAND OR FINGER INJURY. ONLY GRASP PARTS OF THE FRAME OR SADDLE TO LIFT ELECTRIC JUGGERNAUT.

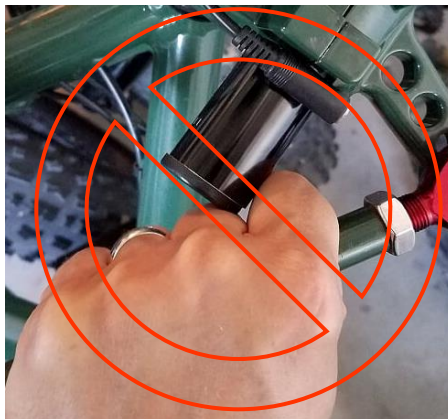
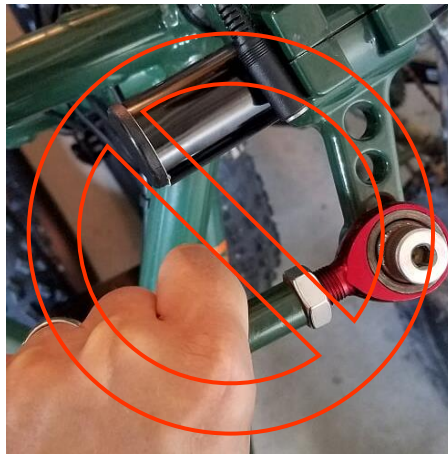

Battery Safety

NOTE: If you ever suspect a battery problem, please contact Rungu Support immediately by email or phone so we can go through the appropriate steps/procedures to make sure everything is okay with the battery system.

At Standard Bearer Machines, safety is our number one concern. Standard Bearer Machines wants our customers to enjoy an excellent product that will give those customers years of trouble-free operation. As much as Standard Bearer Machines and its battery manufacturers invest to minimize the risk of these state-of-the-art batteries, there are always safety concerns with Lithium Ion Batteries. All new portable electronics, including cell phones and laptops, contain lithium batteries. Rungu batteries use the same technology but on a much bigger scale. Standard Bearer Machines makes every effort to have the highest quality battery cells and best battery protection (called a BMS or Battery Management System) to minimize any risk associated with these bigger batteries.

Standard Bearer Machines uses a battery chemistry that is popular with production electric vehicles. The battery chemistry is the same that large car manufacturers (such as Nissan) use in their vehicles. This state-of-the-art battery chemistry is called Lithium Nickel Manganese Cobalt (LiNiMnCoO₂) or LiNMC for short. The electric vehicle industry prefers this chemistry due to the combination of power, safety, performance, and life span compared to the other options available.

Each battery has a Battery Management System (BMS) built into the battery to protect you and the Rungu from dangerous battery faults. Lithium cells have a lot of energy stored in a small package. There is always a possibility a battery cell fault can release this energy and can cause fire and/or severe injury unless the battery is constantly monitored during discharging and charging. The state-of-the-art Battery Management System found on all our battery packs do that. They continuously monitor the cells and pack to avoid failure.

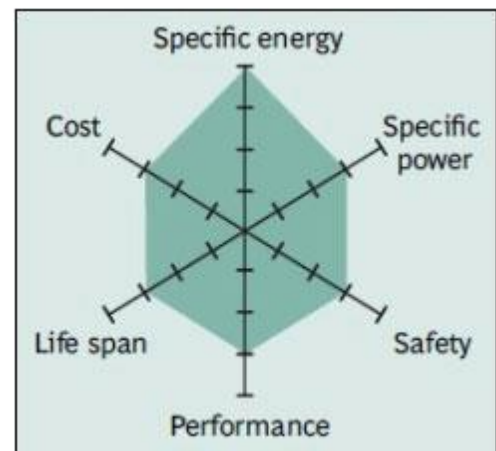

CAUTION: BATTERY PACKS CAN FAIL AS A RESULT OF A BMS FAILURE, PUNCTURE OR DESTRUCTION OF THE BATTERY PACK, OR ATTEMPTING TO CHARGE, SHORT CIRCUIT, OVER DISCHARGE THE BATTERY CELLS IN A WAY THAT DOESN'T USE THE PROTECTIONS OF THE BMS.

The main cause of failure in lithium batteries occurs during the charging portion, when cells can be overcharged. This is the number one failure and can lead to batteries which vent and eventually release all their energy at once (or can even cause the battery pack to catch fire). This can happen if the BMS fails, you try to charge the pack using the output plug instead of the charging plug, or you use a charger that isn't designed to charge lithium ion batteries. Cells in the battery can fall out of balance and result in a cell over charging, which leads to a fire. Standard Bearer Machines always recommends disconnecting the battery and charging it away from the Electric Juggernaut.

CAUTION: CHARGING ON A CONCRETE FLOOR, SUCH AS IN A GARAGE, AWAY FROM DEBRIS AND MATERIAL IS ALWAYS RECOMMENDED AS A SAFETY PRECAUTION.

Battery Safety Precautions

Standard Bearer Machines recommends keeping the following immediately accessible where you charge your bike

- Class D Fire Extinguisher: can be used in the event of a lithium fire
- ABC Fire Extinguisher: If you cannot get a Class D, this will do the job by preventing other materials around the ruptured battery from catching on fire.

If your charger typically takes 4 hours to charge your battery, but it seems to be taking longer, unplug the battery and investigate. If you suspect a bad BMS, smell the top of the battery. If there is a burnt smell, it is a failed BMS and stop charging immediately. If nothing is wrong, it is okay to continue charging as the battery is simply balancing while it is charging and it may take longer than normal.

If you experience a sudden loss of power while riding your Rungu, **STOP IMMEDIATELY**. Turn off the Electric Juggernaut and inspect your battery system. Check for a burnt smell and inspect there are no melted or shorted wires. Shorted wires or a burnt smell indicate a shorted or failed BMS, stop using Rungu and contact us as soon as possible.

If you notice that your battery is swollen, damaged, or smoking contact Rungu Support immediately so we can diagnose the problem and talk you through next steps.

Catastrophic Battery Failure

Although extremely rare, all lithium batteries are capable of catastrophic failure if mishandled or treated. The following are guidelines for a battery pack failure. Great caution needs to be exercised during a catastrophic battery failure.

WARNING: AS SOON AS A PROBLEM IS DETECTED (BATTERY IS HISSING, YOU SMELL A BURNING SMELL, IT IS BILLOWING SMOKE ETC), TAKE BATTERY SYSTEM OR BIKE OUTSIDE IMMEDIATELY, AWAY FROM ALL STRUCTURES AND PEOPLE, PREFERABLY ON CONCRETE (LIKE A DRIVEWAY).

Observe the battery pack from a safe distance. Monitor the battery pack until the cells drop below critical temperature and start to cool off. ***Contact local authorities if necessary!***

Battery Safety (In Depth)

Main reasons a battery packs fail

Battery packs can fail when the BMS fails or is over-ridden allowing the following to occur:

- Short-circuit
- Over-charging – voltage higher than tolerated by cells
- Forced over-discharge – more current than the battery can source
- Excessive heat or incineration
- Crush, puncture, or disassembly

Standard Bearer Machines uses batteries that are tolerant of adverse conditions, but these very active chemical systems have limitations. Certain hazards are associated with exposure to heat and its subsequent effects on sealed cells. These hazards include the potential for cell venting, explosion, and/or fires. The initial source of heat can be external (welding, soldering, etc.) or internal such as heating caused by short circuiting, excessive running currents for prolonged periods of time, forced over-discharge, charging, or excessive mechanical abuse. Specifically, mechanical abuse in the form of excessive shock or vibration can result in case deformation, crushing, and damage to the electrode materials.

WARNING: NOT GUARDING AGAINST THESE CONDITIONS MAY RESULT IN A HOT CELL OR A BATTERY PACK THAT COULD VENT OR EXPLODE.

Only trained and equipped emergency responders should respond to an incident with hot or vented cell. Consult federal, state, and local regulations for emergency response regulations.

Hot Cells

A hot cell is a condition that arises due to a short circuit of the cell or battery, either internal or external. The cell/battery temperature rises as the event continues which can lead to the cell reaching critical temperature and the potential to vent or explode.

Vented Cells

It is unlikely that any lithium battery would explode. These events are rare and are usually the result of an abusive condition or misuse that raises the cell temperature above its critical point.

In the event of a lithium battery explosion, a room can quickly fill with a dense white smoke that can cause severe irritation to the respiratory tract, eyes, and skin. Limit exposure to these fumes.

Battery Failure Response Procedure

WARNING: IF THERE IS A FIRE, STAY AWAY FROM THE SMOKE, FUMES AND FLAMES. CONTACT LOCAL FIRE AUTHORITIES TO PUT OUT THE FIRE.

- Monitor the temperature from a safe distance using a non-contact thermometer or thermal imager
- If temperature monitoring equipment is not available, keep the area evacuated and secure and do not handle the cell/battery for at least 24-hours
- If the battery cools, continue to monitor until it reaches ambient temperature
- Remove the battery from the area once it is cool
- Dispose of the cell in accordance with waste or recycling protocols
- For more information on Lithium batteries, please visit [Battery University](#) as a source of knowledge

Operating Electric Juggernaut

NOTE: Your Electric Juggernaut ships with the batteries partially discharged to allow longer storage. Before riding, fully charge the battery or batteries prior to your first ride.

Charging Your Main Battery – Single battery units (Standard, HC+)

1. Make sure your charger is set to the correct voltage for your country's power requirement. On the back of your battery charger is an input voltage switch. Check that the voltage switch is switched correctly for your voltage standard – 110V refers to 110-120VAC 60Hz common to North America. 220V refers to 220-240VAC 50Hz common to Europe and Asia.



If the voltage input switch is set incorrectly for your voltage standard, use the blade of a small screwdriver to push the switch to the correct setting.

2. Use the keys supplied with your Electric Juggernaut to unlock the battery case from the front. You'll find the lock under the Main Battery Case. Use some pressure to retain the Battery Cover while turning the key.



CAUTION: THE BATTERY HAS PADDING INSIDE OF THE MAIN BATTERY CASE TO MINIMIZE SHOCK AND VIBRATION; TURNING THE KEY MAY REQUIRE THAT YOU OVERCOME THE PRESSURE FROM THIS PADDING. DO NOT REMOVE THE PADDING.

3. Remove the Main Battery Case cover and put it aside.

Note: At this point you can charge the battery inside the Main Battery Case or remove the battery for storage or charging elsewhere. To remove the battery, pull the battery forward and up. Be careful not to drop the battery. When you have removed it from the case, disconnect the large yellow connector connecting the battery to the motor.

CAUTION: IF YOU DECIDE TO REMOVE THE BATTERY, MAKE SURE YOU HAVE THE GRIP AND ARM STRENGTH TO REMOVE IT – THE BATTERY WEIGHS 10 LBS. (4.5 KGS).

4. To charge the battery in place, extend the small yellow connector from the battery.

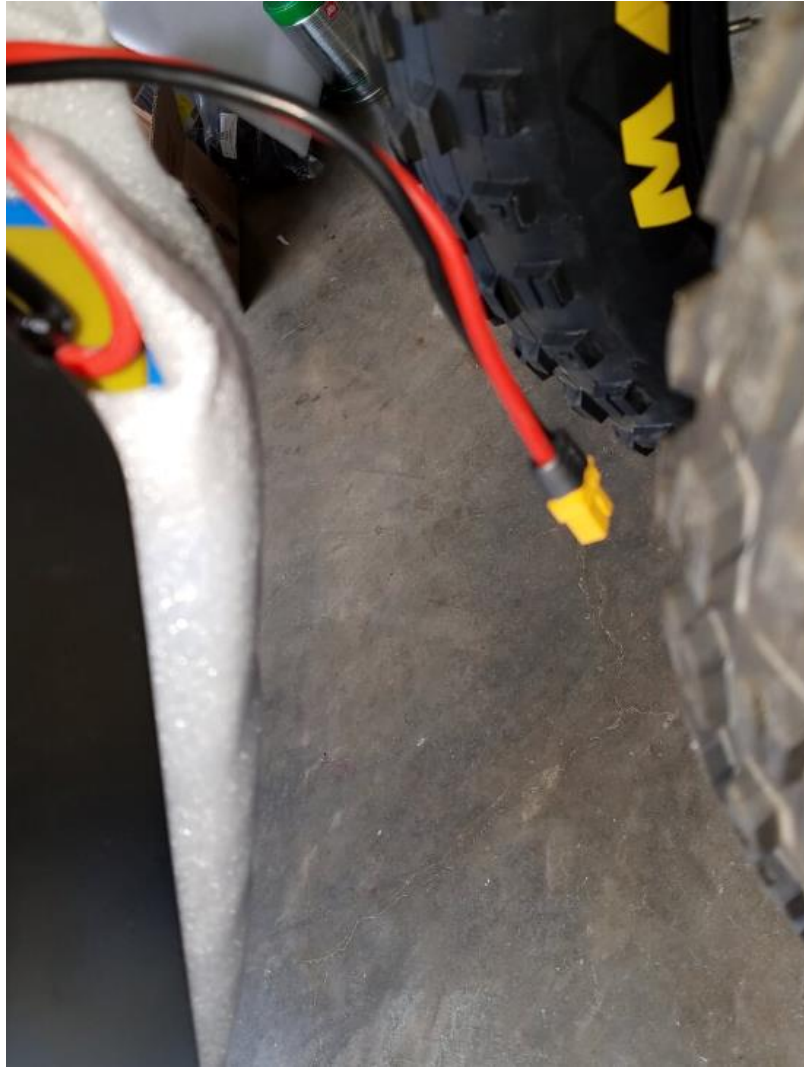

5. Plug the charger plug to the connector extended from the battery. The connector is keyed, so there is only one way that the plug will fit.



WARNING: ONLY USE THIS CONNECTOR TO CHARGE. EVEN THOUGH THESE BATTERIES HAVE BUILT-IN BATTERY MANAGEMENT SYSTEMS, A BMS FAULT OR FAILURE MAY OCCUR. IF YOU EVER NOTICE A BATTERY PUFFING, STOP CHARGING THE BATTERY, PLACE IT OUTSIDE ON CONCRETE A SAFE DISTANCE AWAY AND MONITOR IT CLOSELY FROM A SAFE DISTANCE TO MAKE SURE ALL IS O.K. GIVE US A CALL/EMAIL US IMMEDIATELY IF A BATTERY BEGINS TO PUFF, AND CONTACT RUNGU FOR GUIDANCE ON THE NEXT STEPS. DO NOT ATTEMPT TO USE A BATTERY AFTER IT HAS SWELLED AND EXPANDED OR "PUFFED" SIGNIFICANTLY.

6. Plug the battery charger into an AC wall outlet using the provided AC cord.

WARNING: DO NOT LEAVE CHARGER PLUGGED INTO WALL AFTER CHARGING – THIS MAY DAMAGE THE BATTERY CHARGER. UNPLUG OR OTHERWISE DISCONNECT THE CHARGER FROM AC POWER WHEN IT IS NOT IN USE. FAILURE TO DO SO WILL VOID YOUR WARRANTY.

7. A red light should appear right after you plug in the battery. Wait until the light on the charger turns green for a full charge. Depending on the power of your charger and the amount of charge remaining in your battery, you should expect a full charge in fewer than 4 hours. If it fails to charge, please look at the troubleshooting section for further information.

NOTE: You do not always need to wait for a full charge, you may use your batteries at any time since the batteries have no memory. For extended use, it will always be better to get a full charge so that you do not deplete your batteries too far when you ride. It is better in the long run to use less than 80% capacity of the battery when riding if possible.

CAUTION: REFER TO THE [BATTERY CARE](#) SECTION IN THIS DOCUMENT FOR MORE INSTRUCTIONS ON HOW TO MAXIMIZE THE LIFE OF YOUR BATTERIES.

WARNING: IF YOU FULLY CHARGE THE BATTERY, DISCONNECT THE BATTERY FROM THE CHARGER AS SOON AS POSSIBLE OR WITHIN A FEW HOURS OF COMPLETING A FULL- CHARGE. FAILURE TO DO SO MAY CAUSE THE BATTERY TO SWELL AND FAIL. A SWOLLEN BATTERY IS NOT COVERED BY THE WARRANTY.

8. IF YOU HAVE REMOVED the battery for charging, disconnect the battery from the charger, reconnect the large connector to the motor connector inside the Main Battery Case, and replace the battery inside the Main Battery Case opposite the way you removed it. OTHERWISE, disconnect the battery from the charger and replace the charging cable away inside the main battery case away from the key latch mechanism.

9. Replace the cover by fitting the two tabs into the slots at the bottom of the case



10. Push the cover closed making sure not to pinch any cables or battery padding.

WARNING: TAKE CARE TO PLACE THE CHARGING CABLE AWAY FROM THE LATCH TO AVOID DAMAGING THE CABLE AND SHORTING THE BATTERY. BATTERIES FROM SHORTED CABLES AND SEVERED BATTERY CABLES ARE NOT COVERED BY YOUR RUNGU WARRANTY.

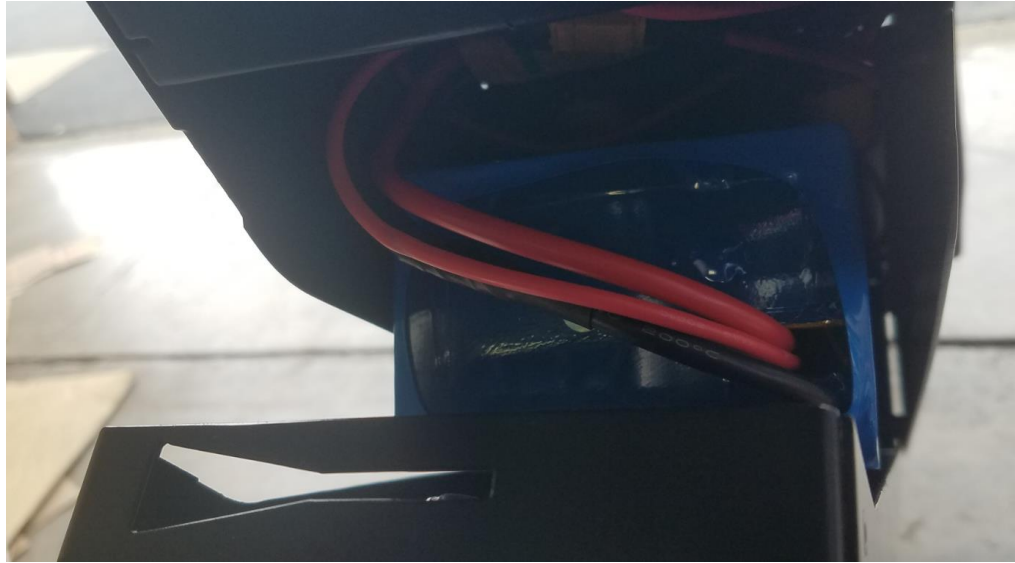

GOOD - cables positioned away from cover



BAD - Cables will be pinched by cover

11. Use the same technique as in step 1 to hold the cover in place while using the key to close the latch.
12. Remove the key from the latch and put it away to avoid losing it.

Charging Dual Batteries – Dual Battery Units (Overland, Rubicon)

Dual battery units have one battery located in the Rungu Cargo Rack and another in the battery case under the frame.

1. Make sure your dual battery chargers are set to the correct voltage for your country's power requirement. Each charger has an input voltage switch. Check that the voltage switch is switched correctly for your voltage standard – 110V refers to 110-120VAC 60Hz common to North America. 220V refers to 220-240VAC 50Hz common to Europe and Asia.



If the voltage input switch is set incorrectly for your voltage standard, use the blade of a small screwdriver to push the switch to the correct setting.

2. Access the charger connectors. Use the keys supplied with your Electric Juggernaut to unlock the battery access door on top of the Rungu Cargo Rack.



Caution: The battery has padding inside of the rack to minimize shock and vibration; turning the key may require that you overcome the pressure from this padding. Do not remove the padding from the battery.

3. Open the door to expose the battery and cabling inside the Rungu Cargo Rack.

Note: At this point you can charge the battery inside the Rungu Cargo Rack or remove the battery for storage or charging elsewhere. To remove the battery, lift the battery up from the front and lift the battery out of the Rungu Cargo Rack. Be careful not to drop the battery. When you have removed it from the rack, disconnect the large yellow connector connecting the battery to the extension cable. To remove the second battery, follow the directions in the [Charging Your Main Battery](#) section earlier in this document.

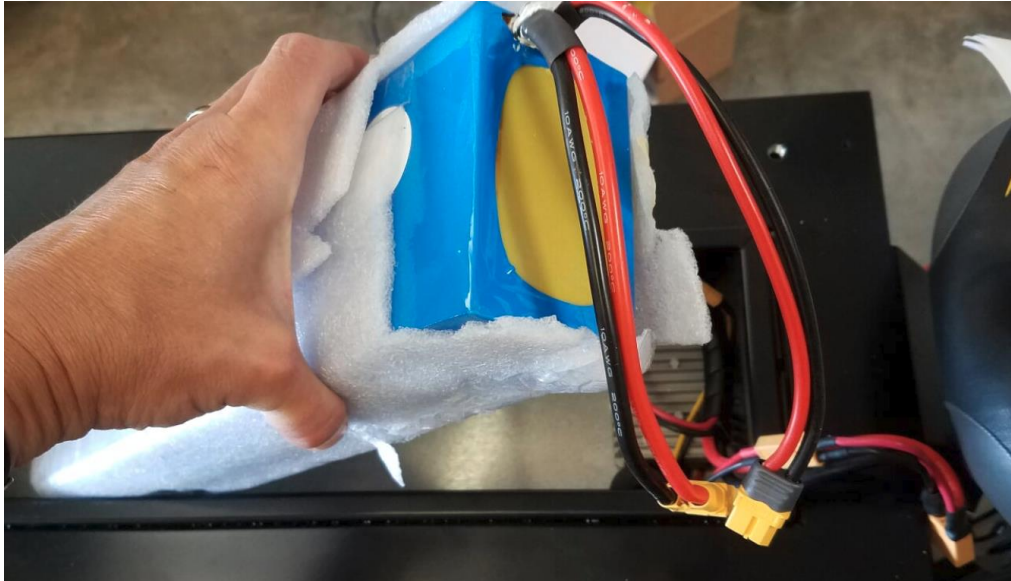

4. To charge both batteries in place, extend the small yellow connector from the battery in the rear rack as well as the one from the second battery, which should be alongside the cable coming from the side of the rack.

CAUTION: IF YOUR RUNGU DOESN'T HAVE THE 12VDC CONVERTER INSTALLED, THERE ARE TWO SIMILAR CABLES WITH THE SAME SMALL YELLOW CONNECTORS THAT COME FROM THE SIDE OF THE RACK. ONE IS INTENDED FOR THE 12VDC CONVERTER. IF YOU DO NOT HAVE THE 12VDC CONVERTER INSTALLED, PLUG THE CHARGER INTO CONNECTOR THAT HAS A DEDICATED CABLE AND NOT THE CONNECTOR ATTACHED AS A PIGTAIL TO THE MAIN POWER CABLE.

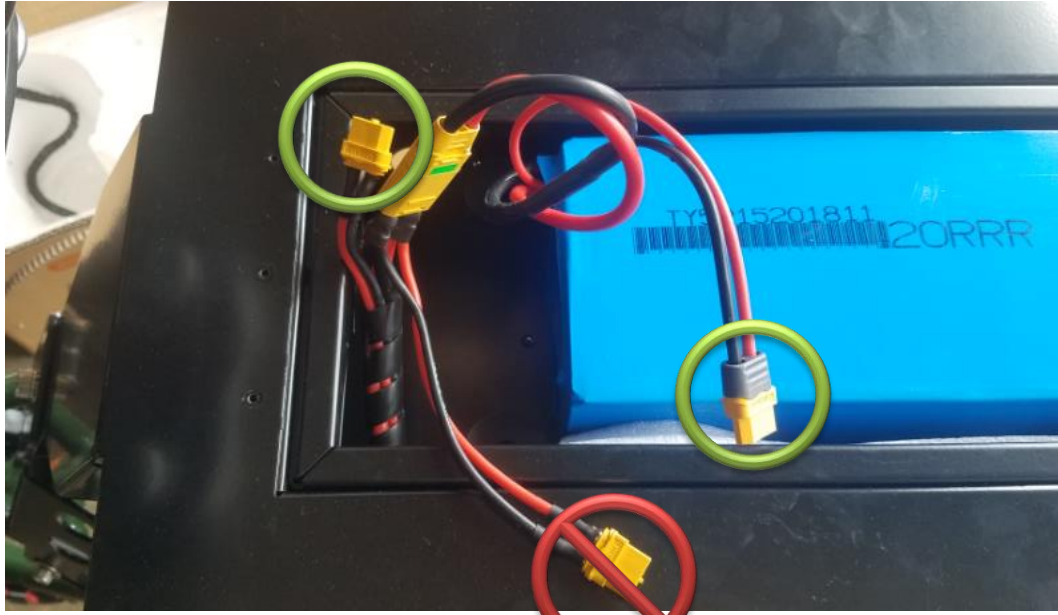

5. Plug the both charger plugs to the connectors shown above.

WARNING: ONLY USE THESE CONNECTORS TO CHARGE. EVEN THOUGH THESE BATTERIES HAVE BUILT-IN BATTERY MANAGEMENT SYSTEMS, A BMS FAULT OR FAILURE MAY OCCUR. IF YOU EVER NOTICE A BATTERY PUFFING, STOP CHARGING THE BATTERY, PLACE IT OUTSIDE ON CONCRETE A SAFE DISTANCE AWAY AND MONITOR IT CLOSELY FROM A SAFE DISTANCE TO MAKE SURE ALL IS O.K. GIVE US A CALL/EMAIL US IMMEDIATELY IF A BATTERY BEGINS TO PUFF, AND CONTACT RUNGU FOR GUIDANCE ON THE NEXT STEPS. DO NOT ATTEMPT TO USE A BATTERY AFTER IT HAS SWELLED AND EXPANDED OR "PUFFED" SIGNIFICANTLY.

6. Plug each battery charger into an AC wall outlet.

WARNING: DO NOT LEAVE CHARGERS PLUGGED INTO WALL AFTER CHARGING – THIS MAY DAMAGE THE BATTERY CHARGER. UNPLUG OR OTHERWISE DISCONNECT THE CHARGER FROM AC POWER WHEN IT IS NOT IN USE. FAILURE TO DO SO WILL VOID YOUR WARRANTY.

7. A red light should appear on each charger within a few seconds. Wait until the light on the charger turns green for a full charge. Depending on the amount of charge remaining in your battery, you should expect a full charge in fewer than 3 hours. If the battery fails to charge or the light fails to turn red, please look at the troubleshooting section for further information.

NOTE: You do not always need to wait for a full charge, you may use your batteries at any time. It is better in the long run to use less than 80% capacity of the battery when riding if possible.

CAUTION: REFER TO THE DOCUMENT "BATTERY CARE AND LONG TERM STORAGE" FOR COMPLETE INSTRUCTIONS ON HOW TO MAXIMIZE THE LIFE OF YOUR BATTERIES.

8. IF YOU HAVE REMOVED the battery for charging, disconnect the battery from the charger and replace the battery in the Cargo Rack compartment. Reconnect the large connector to the motor connector inside the compartment. OTHERWISE, disconnect the battery from the charger. Place all the cables inside the compartment and away from the door and key latch mechanism to avoid pinching cables when closing the door.

WARNING: TAKE CARE TO PLACE THE CHARGING CABLE AWAY FROM THE LATCH TO AVOID DAMAGING THE CABLE AND SHORTING THE BATTERY. BATTERIES FROM SHORTED CABLES AND SEVERED BATTERY CABLES ARE NOT COVERED BY YOUR RUNGU WARRANTY.



GOOD - cables placed away from door and key latch



BAD - cables obstruct door closure

9. Lower the door over the battery.
10. Use the same technique as in step 1 to hold the door in place while using the key to close the latch.
11. Remove the key from the latch and put it away to avoid losing it.

Before your first ride – Safety Check

Note: If you have assembled the Electric Juggernaut yourself, Standard Bearer Machines recommends you take the Electric Juggernaut to a local bike shop for final tuning and adjustment.

As explained in the unpacking and assembly instruction, Standard Bearer Machines recommends the Juggernaut to be assembled professionally once you receive it. The following nine steps are intended to help make your first ride a safe one.

Note: Standard Bearer Machines tune every Rungu prior to shipping. During shipping, shifters, brakes and other mechanical parts may move out of alignment.

1. Make sure the stems are tightly clamped to your forks. To do this, stand in front of the Rungu astride the left wheel facing the steering assembly. Hold both handle bars and try to turn the steering. The fork and wheel should flex, but the handlebars shouldn't turn independently of the wheel you're bracing. If the other wheel moves when you turn the handlebars, STOP. The stems aren't tightened enough; Turn the handlebars back to visually align the two front wheels with handle bars and tighten the two bolts on the back of the stem, where the stem clamps to the fork. Repeat this step for the right wheel.



2. Make sure each wheel is fully inserted into its dropout. Look carefully at both sides of the quick release on each wheel and make sure that the quick release skewer ends are seated inside the recesses on the bottom of the forks for each fork and inside the slot in the frame of the rear dropout for the rear wheel. If they are not, STOP. Unclamp the quick release, reposition the wheel and re-clamp the quick release to retain the wheel.
3. Make sure each quick release skewer is clamping the wheel. The quick releases should be difficult to open. If they are not, STOP. Open the quick release lever and screw in the retention

nut to make the clamping tighter. The quick release should begin to clamp when the quick release lever is pointing perpendicularly away from the Rungu.

4. Ensure that the Linkage Rod Retention Bolts are tightened. Use a ¼" Hex Wrench and check if you can loosen the bolts applying minimal force. If you can, STOP. Tighten each bolt.
5. Make sure the handlebars don't twist in place. Hold each grip and try to twist the handlebars. If they twist, STOP. Re-orient the handlebars according to your preference and re-tighten the four screws on each linkage arm to clamp the handlebars.
6. Make sure the handle bar ends extend past the stems by at least 45 mm (1 ¾"). To check this, move the handle bars to each stop – where the handlebar end contacts the linkage rod. Look to see if the inside of the tire touches the outside of the neighboring fork. If it touches, STOP. Follow the instructions in the assembly section to reposition the handlebar end so that it extends at least 45 mm from the stem.

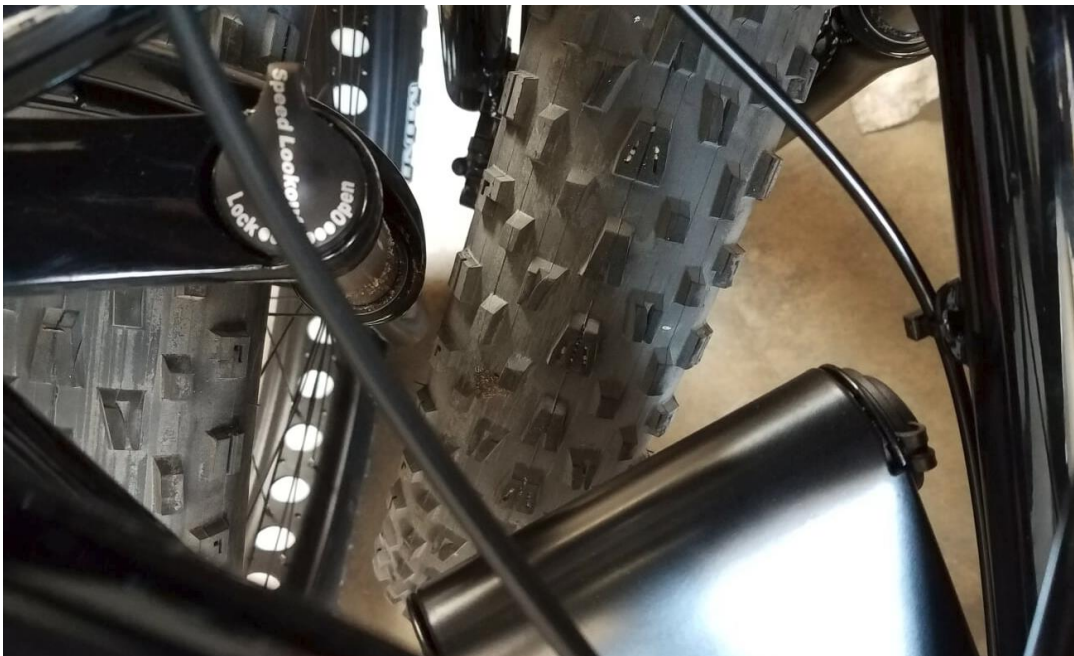

7. Make sure the battery case covers are on and locked in place. Verify that each battery case cover is in place and locked. If not, STOP. Replace and re lock each battery cover making sure to avoid pinching or severing wires.
WARNING: TAKE CARE TO PLACE THE CHARGING CABLE AWAY FROM THE LATCH TO AVOID DAMAGING THE CABLE AND SHORTING THE BATTERY. BATTERIES FROM SHORTED CABLES AND SEVERED BATTERY CABLES ARE NOT COVERED BY YOUR RUNGU WARRANTY.
8. Make sure your seat post and seat are tightened. With the seat post clamp tightened, try to rotate the saddle. If the saddle moves, STOP. Open the seat post clamp and tighten the clamping mechanism before adjusting saddle height and orientation, then clamp it again.

9. Make sure your tires are inflated to the right pressure for the terrain you're going to ride. Use a tire pressure gauge to check the pressure of your tires. If the tire pressure is below 4 PSI or above 15 PSI (103 KPa), STOP. Inflate the tires to be 5 PSI (34 KPa) or above, or release air from the tire to lower the pressure below 15 PSI (103 KPa).

Note: Tire pressure plays a very important role in how you enjoy your Rungu Electric Juggernaut. If you plan to ride mostly on soft ground like sand or snow, use a tire pressure between 5 (34 kPa) and 6 PSI (41 kPa) for best traction and control as well as minimizing tread wear. Use 10 PSI (69 kPa) if you plan to ride on harder surfaces like rock or dirt road. On harder surfaces, a higher pressure minimizes tread wear and improves the range of your Electric Juggernaut.

CAUTION: AVOID UNDERINFLATING AND OVER INFLATING THE TIRES. UNDER INFLATION (BELOW 5 PSI) WILL PREVENT THE TIRE FROM SEATING ON THE TIRE AND PREVENT YOU FROM RIDING ELECTRIC JUGGERNAUT. OVER INFLATION (MORE THAN 15 PSI – 103 KPA) MAY RESULT IN TIRE BLOW-OUT WHILE RIDING.

Using the control keypad and understanding the dashboard

Electric Juggernaut comes with a display and keypad that differs from other manufacturers using Bafang BBSHD motors due to the higher voltages used. The keypad has the on and off switch, controls the power output level of the motor, turns the (optional) Rungu E-Light on and off, and sets up the display settings. This section provides an overview of the controls that gives you enough information to operate your Electric Juggernaut. For detailed instructions refer to the document “Rungu Electric Juggernaut Mid-drive Version Display User Guide”, which is available on your USB document drive.

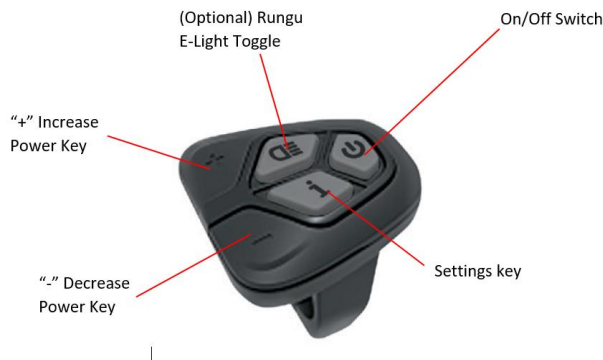

Turning on Electric Juggernaut

Press and hold the on/off switch for one to two seconds. The Display will show a start-up screen and then show the dashboard in green.

Reading the dashboard

When the display turns on, it acts as the dashboard showing all the motor and battery information at any time. This section describes each of the display elements at a high-level. For detailed information refer to the “Rungu Electric Juggernaut Mid-drive Version Display User Guide” document in the USB document drive that accompanied your Electric Juggernaut.



Banner section – Battery and Light status, time

The Battery Indicator on the right side of the banner gives a visual representation of the remaining capacity of the battery. Next to the Battery Indicator is the “State of Charge”, it can show percent of battery charge or the voltage depending on the setting.

Note: Voltage displayed varies up and down during your ride. Rungu “State of Charge” value defaults to showing voltage because the value responds faster to changes in the battery than the Battery Indicator and provides an alternative perspective on how load affects the battery. Electric Juggernaut voltage varies between 42V (fully discharged) and 58~59V. You may observe that voltage drops significantly during a hill climb or when riding on soft surfaces only to rebound afterwards. Voltage drops when the battery experiences greater loading (throttle, hill climbs, etc.), when load is removed a battery “relaxes” and returns to its unloaded voltage.

The e-Light status changes when you turn on the optional Rungu E-Light. When you turn on the optional Rungu E-Light, the image of the headlight appears and the screen dims for night-time riding. You can also set the light to turn on automatically in low-light situations.

The time appears on the left of the banner. You can set the time using the display settings described below.

For detailed information on how to change Display settings, refer to the “Rungu Electric Juggernaut Mid-drive Version Display User Guide” document in the USB document drive that accompanied your Electric Juggernaut.

Center Dial – Speedometer and power meter

In the center of the display appears a graphic representation of Electric Juggernaut speed and battery output power. When riding, the digits in the center will display your speed. Depending on a display setting, the speed appears in miles per hour or kilometers per hour. When riding, a green arc appears and extends clockwise to give a graphic indication of speed relative to maximum speed (also a display setting). On the right side, another arc appears and extends counterclockwise to indicate the battery output power in watts. The amount of power output depends on the power level setting, the terrain, gearing, and the speed you’re trying to maintain.

Footer – Trip information, operating mode and power level

Trip information, the operating mode and the power level appear at the bottom of the display. The display settings control the different measures that appear as trip information – the default is distance (odometer). Press the “i” key repeatedly to sequence through different trip computer output. Finally, the number bracketed in the center is the power level of the motor. The power level at start up is set to 1 - the lowest level of pedal assist. Default power level ranges from 0 (off) to 5 (full power).

CAUTION: RANGE ESTIMATES CAN BE MISLEADING. PRESSING THE “I” KEY CAN CAUSE THE RANGE TO DISPLAY. THIS OUTPUT OF THE TRIP COMPUTER ESTIMATES RANGE REMAINING FOR THE BATTERY CHARGE. THE TRIP COMPUTER CONTINUOUSLY RECALCULATES REMAINING RANGE BASED ON THE WAY YOU HAVE BEEN LOADING THE BATTERY SINCE THE LAST RECHARGE. IF YOUR ROUTE VARIES

AND YOU START BY GOING UP HILL OR THROUGH SOFT TERRAIN, THE COMPUTER ESTIMATES A VERY SHORT RANGE; THE COMPUTER ASSUMES YOUR ROUTE TO CONTINUE TO LOAD THE BATTERY IN THE SAME WAY. IF YOUR ROUTE BEGINS ON A LONG DOWNHILL; THE COMPUTER ASSUMES CONTINUED LIGHT LOADING AND ESTIMATES A VERY LONG RANGE.

Accessing the display settings

To access the display settings, press the “I” button twice in succession within two seconds. The screen shows three settings: Display Setting, Information, and Exit. Navigate the list using the “+” and “-” keys; use the “I” key to make a selection. The Display Setting item has multiple settings that are fully described in the “Rungu Electric Juggernaut Mid-drive Version Display User Guide” manual you can find in your USB document drive or on line at this link.

Toggling the (optional) Rungu E-Light on and off

If you have the Rungu E-Light with your Electric Juggernaut, the Rungu E-Light toggle turns the light on and off. Press and hold the Rungu E-Light toggle for two seconds and release to turn the light on. Do the same to turn it off. The screen will dim when you turn the light on for nighttime visibility.

Choose the AL Sensitivity setting in Display Settings, to have the light turn on automatically in low light environment. The option has five levels of sensitivity so that the light sensor in the display will decide when to turn on the light based on surrounding light levels.

Turning off Electric Juggernaut

Use the on/off key to turn off Electric Juggernaut. Electric Juggernaut also turns off if left idle for a few minutes. Display settings control the amount of time in minutes.

Built-in USB charging port

The Display has a Micro USB charging port under the bottom of the display protected by a rubber cover. Lift the cover to access the port.



You can charge your phone or power a GPS unit with the appropriate cable like the one depicted below for a device that uses a Micro USB port for charging.



PIN Code

You can also prevent accidental or unwanted Electric Juggernaut activation by implementing a PIN code at power-on. Using the Display setting “Password,” set a four digit password for powering Electric Juggernaut. The next time you power Electric Juggernaut, the Display will require you to enter the four digits using the “+” and “-” keys to scroll 0 through 9 and advance to the next digit using the “i” key. The Display Setting item is described in the “Rungu Electric Juggernaut Mid-drive Version Display User Guide” manual you can find in your USB document drive or on line at this link.

Push assistance

Electric Juggernaut can also help you push if you are walking alongside. Hold the “-” key down for more than two seconds; the motor turns and will help you push Electric Juggernaut at approximately 3 miles per hour – walking pace.

Riding Electric Juggernaut

Riding Electric Juggernaut, the first time

Be prepared for a learning curve riding Rungu the first time. Electric Juggernaut rides differently than bicycles and e-bikes and requires five to thirty minutes of riding before feeling comfortable. The additional front wheel adds more inertia to turning; riding Electric Juggernaut feels more like riding a motorcycle than riding a bicycle. We recommend starting on pavement in an area with no other vehicular traffic and using power level 1 only to get used to turning and changing gears.

Watch our introductory video: [RUNGU Electric Juggernaut MDV Learning to ride](#) before your first ride.

Using Gear Shifters

Electric Juggernaut has trigger-style gear shifters common to mountain bicycles; when used, they optimize your Electric Juggernaut riding experience and apply the appropriate power to the appropriate terrain. The shifters let you change the gear ratio between the motor and the rear wheel to best leverage the power coming from the motor regardless the power level. Like the transmission in a car, being in the wrong gear can cause the car to stall or use excessive energy to maintain speed. The same holds true with Electric Juggernaut.

Electric Juggernaut has 10 gears – first gear has the largest sprocket on the rear wheel; tenth uses the smallest. First gear has the lowest gear ratio between the motor and the rear wheel. This gear is used for hill climbing or crossing the most difficult soft terrain. Tenth gear has the highest gear ratio, therefore it's used for cruising on flat roads to achieve the highest speed.

You use your right thumb and index finger to shift gears. Each press of the thumb or pull of the index finger against the shifter indexes the gear. Pressing the shifter with the thumb changes decreases the gear by one starting at tenth gear. Pulling the shifter increases the gear by one starting with first gear.

You can shift gears while pedaling. The shifter controls the rear derailleur, which moves the chain from one gear to the next. The derailleur can move the chain only while the chain is moving. The Mid-Drive motor moves the chain when you throttle or pedal, but Electric Juggernaut also uses an electronic clutch (gearsensor.com) to shut off the motor during each gear change, so you have to pedal in order to complete the gear change. The electronic clutch activation minimizes the force on the chain and sprockets during gear changes to avoid damage to the chain or cassette. It does not prevent overloading conditions if changing gears under heavy load (power level 4 and 5), so avoid changing gears when experiencing heavy load going up hills or deep snow. Read the section below for more information.

Note: Electric Juggernaut Warranty does not cover damaged/worn cassettes and broken chains.

Understanding and changing Electric Juggernaut Power Level

Each Electric Juggernaut is factory configured to five selectable power levels for the mid-drive motor. At the lowest level, the motor provides very little assistance to pedaling. At level 2, Electric Juggernaut can qualify as a “type I”² (Pedelec) electric bike or Throttle Powered “type II”³ electric bike. At levels 4 and 5, you access the full power of the mid-drive motor, which is intended for off-road use only.

Press “+” to increase the power by one level; Press “-” key to decrease the power by one increment. As you’re riding you can increase and decrease the power output of the Electric Juggernaut motor in this way. If you’re operating Electric Juggernaut on flat paved roads, using level 2 or 3 is adequate to maintain a speed of 10 mph with minimal effort. If you’re riding steep inclines off-road or in deep sand/snow, use a combination of appropriate gearing and a power level of four or five. The table below shows the power levels and how they correspond to the maximum power output to the motor:

Power Level	% Maximum Power	Maximum Power (Watts)
0	0%	0
1	20%	336
2	40%	672
3	60%	1008
4	80%	1344
5	100%	1680

Appropriate gearing takes full advantage at each power level. Using the shifter on the right handlebar, you can change the Electric Juggernaut gearing. Electric Juggernaut has ten gear ratios or speeds. In the highest gear (smallest cog) the standard ratio is 42:11 (the optional 30T chainring has a gear ratio of 30:11). For every rotation of the crank arms, the rear wheel turns 3.8 times, which is good for maintaining higher speeds. However, the torque output is 1/3rd of the motor output so acceleration and hill climbing using this gear ratio is a bad idea. In the lowest gear (largest cog), the gear ratio is 42:36 (The optional 30T chainring has a gear ratio of 30:36). For every rotation of the crank arms, the rear wheel turns 1.2 times; not so good for maintaining higher speeds, but great for getting the most torque out of the motor for hill climbs and loose ground. Learn to use the gear shifter to adjust to terrain to take full advantage of each power level you choose.

Note: The optional 30T chainring generates more force for climbing but does not travel as fast as an Electric Juggernaut outfitted with the standard 42T chainring.

² According to California Ebike Standards. Learn more at https://en.wikipedia.org/wiki/Electric_bicycle_laws#California

³ According to California Ebike Standards. Learn more at https://en.wikipedia.org/wiki/Electric_bicycle_laws#California

CAUTION: AVOID SHIFTING WHEN ELECTRIC JUGGERNAUT IS UNDER LOAD. SHIFTING GEARS WHILE USING POWER LEVEL 4 OR 5 AND HILL CLIMBING MAXIMIZES CHAIN WEAR AND MAY RESULT IN A BROKEN CHAIN, BENT CASSETTE COGS OR BOTH. THE ELECTRIC JUGGERNAUT USES A CHAIN DESIGNED FOR THE OUTPUT OF THE MOTOR, HOWEVER REPEATED GEAR CHANGES AT THE HIGHER POWER LEVELS GENERATES VERY HIGH FORCE AND CAN BREAK A LINK. IF YOU PLAN TO OPERATE ELECTRIC JUGGERNAUT IN DIFFICULT OR CHALLENGING TERRAIN BE PREPARED ALWAYS AND CARRY AN EXTRA CHAIN FOR REPLACEMENT.



Bent 3rd gear cog resulting from gear change while hill-climbing and power level set to 5

CAUTION: AVOID ACCELERATING AND PROLONGED USE OF 9TH AND 10TH GEAR WHILE POWER LEVEL SET TO 4 OR 5. POWER LEVELS 4 AND 5 PRODUCE SIGNIFICANT FORCE ON THE TWO SMALLEST COGS AND LEAD TO RAPID COG WEAR AND RESULT IN INCONSISTENT CHAIN ENGAGEMENT (CHAIN SKIPS). YOUR WARRANTY DOES NOT COVER DAMAGE TO THE CASSETTE DUE TO WEAR OR LOADING.



New 10th speed cog



Same cog after three miles of heavy operation using power level 5. Note tooth damage.

In the Display Settings, you can also change the number of Power Level increments with the MAX PAS setting. Electric Juggernaut default is five, but you can also have three settings (33%, 67%, 100%) or nine settings in 10% increments.

For detailed information on how to change Display settings, refer to the “Rungu Electric Juggernaut Mid-drive Version Display User Guide” document in the USB document drive that accompanied your Electric Juggernaut.

Power level and gear combination guidelines

For best results and the longest life of your chain and cassette follow these guidelines:

1. ON EVEN OR ROLLING ROADS, Use power level 3 (60%) and pedal. Change gears at will to manage speed. Avoid power levels 4 (80%) and 5 (100%) when using 9th or 10th gear. The force of acceleration at high power levels on these small cassette sprockets leads to premature wear.
2. ON STEEP HILLS (greater than 20% grade), stay in first or second gear and leave the power level set to 5 (100%). Avoid changing gears. Changing gears under load may cause the chain to break or the sprockets in the cassette to bend. If you plan to ride off-road and encounter steep terrain, it is advisable to bring a spare chain and a master link chain tool. The chain tool can also be used to straighten out bent sprockets.
3. ON LOOSE GROUND LIKE DEEP SNOW OR SOFT SAND, use power levels 3-5 and low tire pressures (as discussed above), always start in first or second gear before changing gears to get a higher speed. As with steep hills, changing gears under load may cause the chain to break or the sprockets in the cassette to bend.

Electric Juggernaut Operation Cautions

1. DO NOT use FULL throttle for prolonged periods of time. This will result in excessive heat buildup in the motor, throttle and batteries. Think about what would happen to your car if you redlined for prolonged periods of time... the engine won't last long. Do not abuse your system, and it will last you a long time!
2. DO NOT operate in excessive heat (over 100 degrees Fahrenheit) for a prolonged period of time. Doing so may result in excessive heat buildup and some components may shut down due to thermal protection.
3. If you notice a decrease in performance or abnormal operation, cease electrical operation immediately. Failure to do so may result in damage to electrical components.
4. DO NOT apply the brakes abruptly when going downhill as this may result in loss of control. Use consistent, gradual braking.
5. For best results and the longest life of your chain and cassette follow these guidelines:
 - a. ON EVEN OR ROLLING ROADS, Use power level 3 (60%) and pedal. Change gears at will to manage speed. Avoid power levels 4 (80%) and 5 (100%) when using 9th or 10th gear. The force of acceleration at high power levels on these small cassette sprockets leads to premature wear.
 - b. ON STEEP HILLS (greater than 20% grade), stay in first or second gear and leave the power level set to 5 (100%). Avoid changing gears. Changing gears under load may cause the chain to break or the sprockets in the cassette to bend. If you plan to ride off-road and encounter steep terrain, it is advisable to bring a spare chain and a master link chain tool. The chain tool can also be used to straighten out bent sprockets.
 - c. ON LOOSE GROUND LIKE DEEP SNOW OR SOFT SAND, use power levels 3-5 and low tire pressures (as discussed above), always start in first or second gear before changing gears to get a higher speed. As with steep hills, changing gears under load may cause the chain to break or the sprockets in the cassette to bend.

Ride Electric Juggernaut at a level and speed you are comfortable with. If you're uncomfortable with the terrain, walk the bike.

Note: Electric Juggernaut Warranty does not cover damaged/worn cassettes and broken chains.

6. NEVER jump with the Electric Juggernaut. The Electric Juggernaut is designed for moderate bumps but jumping your Electric Juggernaut can lead to serious injury and/or damage.
7. ALWAYS follow local laws regarding your Electric Juggernaut. If your Electric Juggernaut is over legal speed and power limits, reduce your power level to legal limits when riding on public roads or property.
8. MINIMIZE shifting gears at power level 5 to increase chain life.

Riding Safety

Follow these guidelines to improve your safety when riding Electric Juggernaut

1. ALWAYS wear proper safety equipment
2. NEVER operate at speeds that exceed your ability to operate Electric Juggernaut safely
3. ALWAYS know your surrounding and actively scan the terrain for obstacles
4. DO NOT wear loose fitting clothes or articles
5. NEVER ride with more than 1 rider
6. Suitable for riders 16 and older.
7. Know your Electric Juggernaut and your personal limits

WARNING: DO NOT RIDE AT NIGHT WITHOUT APPROPRIATE REFLECTORS AND LIGHTING. STANDARD BEARER MACHINES DOES NOT SHIP THE STANDARD VERSION OF THE ELECTRIC JUGGERNAUT WITH ANY COMPONENTS FOR NIGHT-TIME RIDING SAFETY. IT IS THE OWNER'S RESPONSIBILITY TO EQUIP ELECTRIC JUGGERNAUT WITH APPROPRIATE REFLECTORS AND LIGHTING TO RIDE SAFETY AT NIGHT.

WARNING: IF ANY INJURIES OR HARM OCCUR WHEN YOU USE THE PRODUCT, Standard Bearer Machines OR ITS DISTRIBUTOR WILL NOT BEAR ANY RESPONSIBILITY

Adjusting the Front Suspension

The front suspension has two manual controls that can change ride and handling characteristics. Looking from above astride the Electric Juggernaut, the right-side knob controls the stiffness of the suspension. The left side switch is used to disable/enable the suspension.



To stiffen or loosen the suspension, turn the right-side knob clockwise or counter-clockwise respectively. All Electric Juggernauts ship with the suspension at the loosest setting. If you find that the front-end dives too much, or that you are having difficulty turning on soft ground (sand, snow), increase the stiffness of both forks by turning the knob clockwise.

When activated, the optional front suspension for the Electric Juggernaut makes cornering on hard surfaces smooth and improves

control on soft sand. Under some circumstances such as when the rear wheel drifts sideways in very soft sand, the suspension may make it difficult to stay upright. Under these circumstances, Rungu recommends disabling the front suspension by turning the switch from the Open position to the Lock position.



Using the parking brake switch

The front or rear hydraulic brake (or both) levers have a parking brake switch. To operate the switch, hold in the brake lever and flip the switch. The switch holds the brake lever in place, which holds the rotor in place and prevents Electric Juggernaut from moving when parked. The parking brake is very useful when parking on angle. REMEMBER to switch off the parking brake before riding. Engaging either front or rear brake disables the motor.

NOTE: Riding with the parking brake engaged produces significant wear on the brake pads leading to a decrease in brake pad life and stopping power. Warranty DOES NOT cover replacement brake pads.

Using the optional 12VDC outlet



The optional 12VDC outlet, located on the top right corner of the battery case under the frame, provides up to 120W of power, which is enough to power a portable air compressor or low power DC/AC inverters. Access the outlet by lifting the tab/covering of the outlet and inserting the appropriate 12VDC charger connector. Charger connectors that fit in a car work in the 12VDC outlet.

CAUTION: THE OUTLET IS LIMITED TO 10A OF OUTPUT. DO NOT USE THE OUTLET FOR ACTIVITIES REQUIRING MORE THAN 10A OF CURRENT SUCH AS JUMP-STARTERS OR HIGHER POWER INVERTERS.

WARNING: DO NOT PUT YOUR BODY PARTS OR METAL OBJECTS IN THE 12VDC – THIS MAY RESULT IN ELECTRICAL SHOCK AND DESTRUCTION OF THE 12VDC OUTLET.

WARNING: DO NOT IMMERSE THE 12VDC OUTLET IN WATER. IMMERSION WILL DAMAGE THE OUTLET AND VOIDS THE WARRANTY.

Rungu Electric Juggernaut Maintenance and Care

Before Each Ride

See section labeled “[Before your first ride – Safety Check](#)”

After Each Ride

1. Clean and inspect Electric Juggernaut. Hose off (Use a shower mode or light spray, avoid powerful spray settings) or wipe down Electric Juggernaut and dry it with a towel. Look for any damage to the frame or components that may need maintenance.
2. Wipe and lubricate the chain. Depending on the riding environment apply a dry or wet lubricant after wiping the chain clean and dry. We use brands like Boeshield T-9 and White Lightning; there are others with similar reputations available worldwide on line.

Battery Care

There are three rules to extend battery life in day to day use:

1. Charge the batteries in a cool, dry location. Heat is not a friend of the charger or the battery.
2. Only fully charge the batteries if you plan to use the Electric Juggernaut within the next few days.
3. If you plan to not use the Electric Juggernaut for more than a few days, keep the batteries charged around 50% of their capacity (Voltage level of 50-52 V) and recharge the battery the day before your next ride.

CAUTION: IT IS IMPORTANT THAT THE BATTERY CHARGER GETS AIR FLOWING OVER THE HEATSINK AND IS OUT OF DIRECT SUN TO AVOID OVERHEATING OR BATTERY FAILURE

WARNING: NEVER CHARGE BATTERIES AT TEMPERATURES AT OR BELOW FREEZING (32°F OR 0°C). CHARGING AT THESE TEMPERATURES CAUSES PERMANENT DAMAGE TO THE BATTERY REDUCING LIFE AND CAPACITY. BATTERY DAMAGE IS EXCLUDED FROM YOUR WARRANTY.

Storage When Not Using Electric Juggernaut for Periods of Two Weeks or Longer

Standard Bearer Machines selected these batteries and the electrical system to be as maintenance free as possible. In the event you plan to not use the Electric Juggernaut for a period of more than three weeks, open the battery case (or cases), disconnect the battery from both connectors, and remove the battery(ies) and store it (them) with ~50% charge (around 50-52V). For long term storage (for the winter) store batteries in a room temperature location and away from Electric Juggernaut. For best results, every month you don't use Electric Juggernaut, hook the battery up to the charger for 10-20 minutes as the battery will lose charge over time and this will allow you to put some extra charge in the battery and balance the cells.

Note: You can purchase an outlet timer that switches the charger on every week for a period of 10 minutes and keep the charger connected to the battery. In this situation, the charger is only powered by AC when the outlet timer is on.

Prolonging the Life of your Battery – Best Practices

The Electric Juggernaut features powerful, light-weight and high-performing batteries. NMC based systems should expect around 3-5 years of use depending on how you take care of your battery and up to 800 charge cycles. These batteries do have a shelf life so even if you are not using the pack, the battery will only be good for so long.

To prolong the life and performance of the pack, it is best to not drain the pack to zero capacity (like when the battery management system shuts it off). Going from 100% to zero capacity will adversely affect your life cycles. It is much better, for instance, to go from 100% to 50%. If you only rode your bike 3 miles every day, you are better off charging the battery after each ride instead of waiting until the battery is dead. Keeping the depth of discharge less than 80% (so from 100% to 20%) will make sure you get the full life from the battery.

Heat and discharge rate also will adversely affect the life and performance of the battery. If you want more life from your battery and system, it is best to use a lower power level. The lower the power level, the less stress (and heat) it puts on the battery cells and battery management system. This equates to a longer cycle life and better performing battery.

Maintenance – After strenuous rides, and every 500 miles or six months

1. ALWAYS check the integrity of the battery case and battery system. Make sure the battery padding is usable, and each battery is secured well in its case. If you notice wear marks on the battery casing, Use duct tape to cover the wear marks and add padding in the wear area (packing foam is fine).
2. Check spokes on all three wheels. The electric wheel often requires more attention due to the torque of the motor. Spoke and wheel maintenance are part of a normal bicycle maintenance procedure and will be accelerated with an electric motor. Do not take chances with the spokes and if you think they are loose, chances are you are correct. The spokes should all have the same tension. If they are loose, tighten them yourself, or take it to your local bike shop to get fixed.
3. Check and replace tires as necessary.
4. Check all electrical connections making sure that they are all tight. Bad contact means energy is wasted as heat, which can cause a breakdown of wire insulation. Any wire with melted insulation indicates a poor connection nearby. Disconnect the batteries and do not operate if insulation is melted or wire is exposed.
5. Clean, inspect and lubricate your chain, or if necessary, replace the chain. Clean the chain with a brush and an over the counter chain cleaning solution. If you observe gear changes to take longer than normal, it may be time to replace the chain. Contact support@riderungu.com or consult the Internet for the most appropriate replacement chain on the market at the time.
6. Inspect the cassette cogs for wear. If you experience chain skip at higher power levels, your cassette cogs may be worn and require replacement. Contact support@riderungu.com, a qualified bicycle technician, or the Internet on sourcing and exchanging your replacement cassette.
7. Service your brakes and brake pads. You can source maintenance supplies from Rungu, but Bicycle stores also have equipment to bleed the hydraulic system and replace the mineral oil.

The same is true for brake pads. Check the components tab on the Support page of the Rungu Website to find links to useful maintenance videos appropriate for the Electric Juggernaut. Standard Bearer Machines periodically updates these links, if you cannot find information you need send an email to support@riderungu.com.

Securing your Electric Juggernaut

When riding the Electric Juggernaut in areas where theft is a concern, use appropriate cable or chain locking devices and make sure to thread the cable/or chain through the frame, wheels and saddle/seatpost to avoid quick removal.

Standard Bearer Machines recommends you use the Password feature found in the display settings described in an earlier section of this document.

Rear wheel removal or replacement

You may have to remove the rear wheel to fix a flat, replace the tire or replace the cassette. The Electric Juggernaut uses a wheel rotation sensor to calculate and display your speedometer. The sensor may impede removal of the rear wheel, so these directions explain the steps to remove and replace the rear wheel in a way that minimizes the need for sensor re-alignment after replacement of the wheel.

Tools required:

- 4mm Hex Wrench
- 5mm Hex Wrench
- 6mm Hex Wrench
- Wire cutters
- Zip ties

How to remove the rear wheel

1. First, make sure the chain is in 10th gear as shown below. Whether or not the chain is on the Rungu, shifting to 10th gear before wheel removal makes wheel removal easier.



2. If possible, find an object (e.g. empty bucket, cardboard box) that you can use to support the bike after the rear wheel is removed. Alternatively, hang the rear triangle from straps or ropes to support the rear triangle after the rear wheel is removed.



3. Use a 4 mm Hex wrench to remove the sensor retention screw from the sensor retainer.



4. Remove the retention bracket. Be careful not to lose the embedded nut on the far side of the bracket. Replace the bolt into the retention bracket and thread it into the nut then put them aside to avoid losing them.



Embedded nut

5. Let the sensor assembly dangle underneath the frame while you remove the rear wheel.



6. IF YOUR RUNGU DOES NOT HAVE A CARGO RACK SKIP TO STEP 7. Remove the cargo rack and place it to one side. For units with a battery in the cargo rack, cut the zip ties securing cabling to the left side stay so that you can remove the rack and place it to one side. To remove the rack, use a 6 mm Hex wrench remove the three M8 bolts. Place the bolts and the star washers aside or mount them to the surface of the rack so you don't lose them.



7. Recommended: Use a 5mm Hex wrench to loosen and remove the two screws supporting the caliper support bracket on the left side of the bike.



Note: If there are washers used to standoff the bracket, make sure to remove them and replace them in the same location when replacing the brake caliper. FAILURE TO DO SO MAY RESULT IN PERMANENT DAMAGE TO THE BRAKE ROTOR, CALIPER OR BOTH.

8. Remove the brake caliper and support bracket to the outside of the frame.



9. Loosen and remove the quick release skewer from the rear wheel. Be careful to not lose the springs or other components of the skewer.



10. Push down on the rear tire so that the wheel falls out of the rear dropouts onto the derailleur.



11. Push the wheel past the derailleur and remove the chain from the rear cassette.

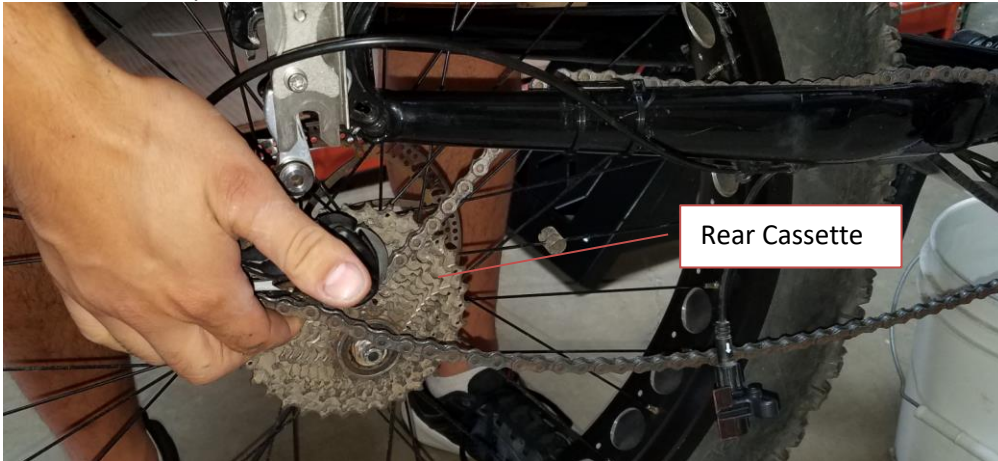

12. Put the rear wheel aside and support the frame as noted above while you service the rear wheel.

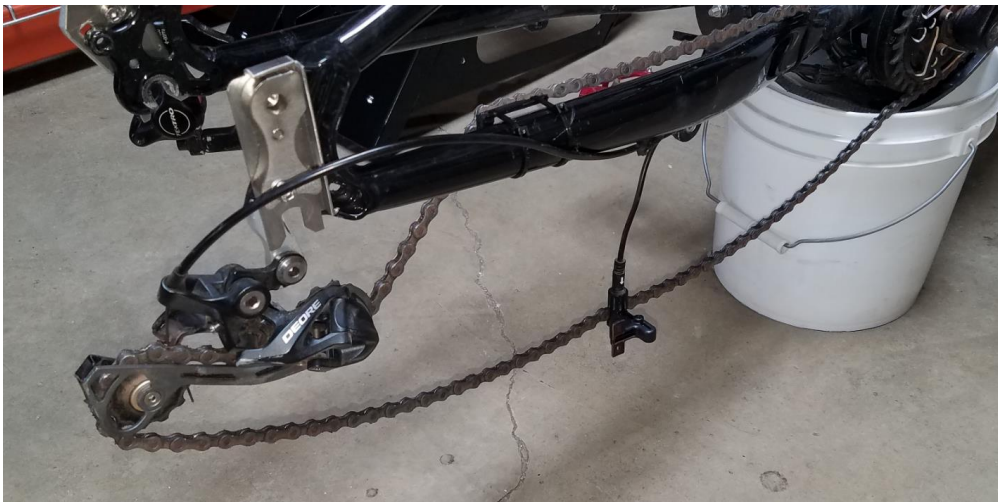

How to replace the rear wheel

1. Lift the rear of the frame and position the rear wheel underneath so that the rear cassette is in placed inside the chain loop.



2. Move the wheel up into the dropouts.



3. Remove the support under the frame so that the rear wheel supports the bike.
4. Replace the quick release skewer into the axle and align the rear wheel to the frame so that it appears vertical and in parallel to the seat tube.



5. If the wheel doesn't appear to be vertical as in the picture below, loosen the quick release, realign and re-tighten the quick release.



- Slide the brake caliper over the rotor so that the caliper support bracket slides between the rotor and the frame.



- Use a 5 mm Hex wrench to replace the two M6 screws you removed from the support bracket during wheel removal.



Note: if you removed spacing washers when removing the caliper, remember to replace them in between the caliper support and the frame when fastening the retention screws.

CAUTION: IF YOU NOTICE THAT TIGHTENING THE FASTENERS CAUSES THE CALIPER TO INTERFERE OR FLEX THE ROTOR, STOP. EITHER RELEASE THE QUICK RELEASE SKEWER AND REALIGN THE REAR WHEEL SO THAT THERE IS NO FLEX OR INTERFERENCE BETWEEN THE ROTOR AND THE CALIPER OR PERFORM THIS STEP IN COMBINATION WITH A BRAKE CALIPER RE-ALIGNMENT.

8. If you have a cargo rack, replace it onto the frame. If your cargo rack contains a spare battery, remember to use zip ties to tie the battery extension cable to the frame on the left stay.



9. Replace the sensor assembly onto the sensor retainer.



10. Replace the sensor retention bracket on top of the sensor and retainer making sure that the embedded nut is in place on the far side of the bracket.



11. Insert the retention bracket screw while placing one finger over the embedded nut to prevent the nut from dropping out.



12. Use a 4 mm Hex wrench to fasten the M5 screw to the nut.
13. After checking that the brake caliper, rear wheel and sensor retainers are fastened tightly, test ride the Rungu to make sure the speedometer is working. Continue to the section Wheel speed sensor alignment, if not.

Wheel speed sensor alignment

Wheel speed sensor alignment is critical to the function of your speedometer. The wheel speed sensor underneath the frame interacts with a magnet mounted onto one spoke on the rear wheel of your Electric Juggernaut. The speedometer calculates your speed using this sensor and magnet to count rotations/second and translate that in real-time to your actual speed in mph (kph). If the speed sensor is not aligned with the magnet or the magnet is too far away from the sensor surface, the speedometer will fail to operate and you will see “Error 21” appear on your display.

Though we align and test all sensor and magnets at the factory, wheel removal or another accident may result in “Error 21”. The steps below explain how to realign the sensor and magnet.

Tools required:

- #2 Philips screwdriver
 - Wire cutters
 - Zip ties
1. Check that the sensor is in place. It is found under the right side chain stay. Check the image below and verify the same sensor is on your Electric Juggernaut. If not contact Rungu or go online to obtain a replacement sensor.



2. Check that the cabling attached to the sensor is attached to the motor.
3. Check the picture below and verify your rear wheel has a magnet attached to one spoke. If you cannot find the magnet on one of the spokes, reorder one from Rungu or other sources online before proceeding.



4. If you are replacing a magnet place the magnet up to an inch in front of where the spokes cross on the rear wheel with the magnetic surface facing out to the right side of the bike.



5. To realign the speed sensor, use wire cutters to clip the zip ties supporting the speed sensor mount and remove them from the speed sensor mount.
6. Thread new zip ties into the speed sensor mount.



7. Place the sensor assembly under the right chainstay and fasten the zip ties so that the assembly is attached to the chainstay, but do not tighten the zip ties until the sensor is properly aligned.\



8. Align the sensor assembly so that the round section facing the wheel is aligned with the face of the magnet.



9. Tighten the zip ties and ensure that the sensor remains aligned with the magnet.
10. Finally, extend the head of the sensor so there is less than an 1/8" (3mm) between the sensor surface and the magnet surface. To do this, use a #2 philips screw driver to loosen the sensor head retention screw under the assembly.



11. Extend the sensor to bring the sensor closer to the magnet as depicted below. Retighten the sensor head retention screw.

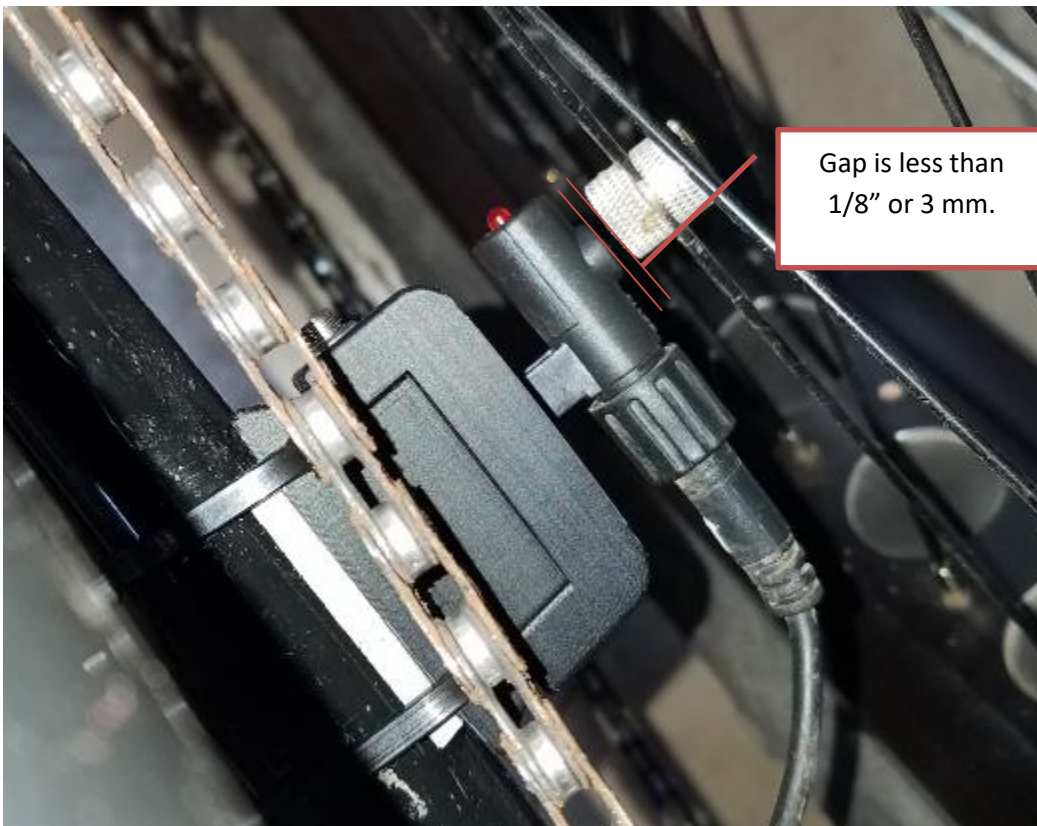

Technical Information

Default Display Settings

Units: Imperial
 Brightness: 100%
 MAX PAS: 5
 Auto Off: 2 minutes
 Power View: Power
 SOC View: %
 Trip Reset: No
 AL Sensitivity: Off
 Password: None

Dimensions

Feature/spec	Electric Juggernaut MDV Standard	Electric Juggernaut MDVHC+	Electric Juggernaut Overland	Electric Juggernaut Rubicon Trail Edition
Projected length	84 in. (2134 mm)			
Projected width	32.7 in. (830 mm)			
Handle bar width (effective)	32.7 in. (830 mm)			
Unit weight with no accessories	85.2 lbs. (38.7 kg)	88.2 lbs. (40 kg)	106.3 lbs. (48.2 kg)	111.7 lbs. (50.7kg)
Frame size	14.5 in. (368 mm)			
Seat tube length (center to top)	13.4 in. (341 mm)			
Bottom bracket height	13.1 in. (332 mm)			
Chainstay length	22.4 in. (569 mm)			
Head tube angle	66°			
Head tube length	7.6 in. (193 mm)			
Seat post length	15.7 in. (400 mm)			
Seat tube angle	73°			
Top tube effective length (horizontal projection)	23.3 in. (592 mm)			
Ground clearance	9 in. (229 mm)			8 in. (203 mm)
Wheel base	54.7 in. (1390 mm)			

Performance

Feature/spec	Kilimanjaro	Juggernaut	Electric Kilimanjaro MDV	Electric Juggernaut MDV Standard	Electric Juggernaut MDVHC+	Electric Juggernaut Overland	Electric Juggernaut Rubicon Trail Edition	Electric Juggernaut SC
Estimated range on pavement with pedal-assist ¹	N/A		119 mi @ 10 mph (192 km)	119 mi @ 10 mph (192 km)	231 mi @ 7 mph (372 km)	388 mi @ 7 mph (624 km)	370 mi @ 7 mph (595 km)	Varies
Estimated off road range with pedal-assist ¹	N/A		20.2 mi @ 10 mph (32.5 km)	20.2 mi @ 10 mph (32.5 km)	21.8 mi @ 7 mph (35 km)	40.3 mi @ 7 mph (65 km)	39.4 mi @ 7 mph (63 km)	Varies
Max range off road - throttle-only ¹	N/A		17.9 mi @ 10 mph (28.8 km)	17.9 mi @ 10 mph (28.8 km)	18.1 mi @ 7 mph (29.1 km)	34 mi @ 7 mph (55 km)	33.4 mi @ 7 mph (54 km)	Varies
Max climbing grade ²	N/A		32%	32%	40%+	40%+	40%+	40%+
Top speed - off-road ³	N/A		23 mph (37 kph)	25 mph (40 kph)	23 mph (37 kph)	22 mph (35 kph)	22 mph (35 kph)	Electronically limited to 27 mph
Max power output (W) ⁴	N/A				1429			4,791
Max power output (Hp) ⁴	N/A				2			4.6
Rotational speed at max power out (RPM)	N/A				121			Varies
Max torque at start (Nm)	N/A				197			329
Max torque at wheel (Nm)	N/A		169 ⁵	169 ⁵	236 ⁶	236 ⁶	236 ⁶	368 ⁶
Max weight supported (rider and cargo)			350 lbs. (159 kg)		344 lbs. (156 kg)	332 lbs. (151 kg)	332 lbs. (151 kg)	Varies
Max towing weight - hitch on rack			N/A		300 lbs. (136 kg)	300 lbs. (136 kg)	300 lbs. (136 kg)	300 lbs. (136 kg)
Max load - Rungu Rear Rack			N/A		180 lbs. (81.6 kg)	170 lbs. (77 kg)	170 lbs. (77 kg)	Varies
Operating Temperature - 52V systems			-20° C to 45° C (-4° F to 113° F)					Varies
Minimum and maximum charging temperatures - 52V systems			0° C to 55° C (32° F to 131° F)					Varies

¹ Estimate based on experience and calculation of maximum range for Rungu carrying 175 lbs. load, on flat dirt track or pavement, no

² Based on experience and calculations. Conditions include load limited to 175 lbs., hard surface, speed of 3 mph and slope distance of 50 ft. Actual maximum climbing grade may differ.

³ Based on experience and calculations. Throttle-only speed for 175 lb. load, on flat dirt road, with no wind. Actual top speed may differ.

⁴ At full charge of 58.8V, 33A input at 121 rpm output

⁵ At minimal gear ratio for model 1:0.85

⁶ At minimal gear ratio for model 1:1.2

Electrical

Feature/spec	Electric Juggernaut MDV Standard	Electric Juggernaut MDVHC+	Electric Juggernaut Overland	Electric Juggernaut Rubicon Trail Edition
Nominal voltage (V)			52	
Max voltage (V)			59	
Max input current (A)			28	
Max power input (W)			1652	
Max efficiency			88%	

Troubleshooting

Electrical

Problem: Why won't my Electric Juggernaut turn on?

After pressing the on/off key, the display fails to light up; no power is coming to the motor.

Solution:

1. Press and hold the on/off key for at least two seconds. If that fails to turn on the display,
2. Check the connector to the Display. Reconnect if disconnected, otherwise,
3. Open the battery case under the frame and remove the battery to make sure the main connector from the battery output lead is plugged in and secure. Inspect the wiring to look for severed wires and make sure the large yellow connectors are connected.
 - a. If your Rungu has one battery, disconnect the large yellow connector - the battery from the controller - and then reconnect the battery. Then press and hold the on/off key. If that fails to turn on the display, continue to step 4
 - b. For two battery systems, disconnect the large yellow connector from both batteries. Then connect each battery in turn. Press and hold the on/off key. If that fails to turn on the display,
4. Check that the battery is fully charged. Use a voltmeter and test the output on the charging terminals if you do not have an ebike computer. If the voltage is at or below 42V, the battery is fully discharged. If you are having trouble charging the battery, please look below about charging your battery.
5. If none of the proposed solutions work, contact Rungu.

Problem: I drove my Electric Juggernaut until it went completely dead and now it will not charge.

This is a problem that occurs when you fully deplete the battery. The BMS on the battery protects the battery from discharging any further and force shuts itself off.

Solution:

Reset your battery by opening removing it from the battery case and disconnecting the battery from the controller (large yellow connectors) and then reconnecting the battery. In most cases, this action is sufficient to "wake up" the battery so it will charge again. If this action fails to work, contact Rungu.

Problem: I cannot get my battery to charge or my charger is not working

The green light stays on when I know the battery is discharged or no light turns on at all when I plug the battery into the charger.

Solution:

1. If no light turns on when you plug the charger into the battery after plugging the charger into AC, replace the fuse in your charger. Then try charging the battery again. If this fails to charge the battery,
2. Reset the battery (see above), and then plug it into the charger. If this fails to charge the battery,
3. Call Rungu to talk through other troubleshooting steps.

Motor and System Performance

Problem: The Electric Juggernaut feels sluggish in difficult environments

Hills, snow, and soft sand will slow down the Electric Juggernaut and cause you to use more power and pedaling. This is normal. If you feel like you have experienced better power in the past check the following items

Solution:

1. Change to a lower gear.
2. Check the power level setting and make sure is at its highest setting.
3. Check that the Battery voltage is greater than 52V. IF the battery is discharged, you'll have less performance than when its charged.

Problem: The display shows “Error 21 – Speed Sensor not functioning”, but Electric Juggernaut continues to work.

The speed sensor has become unattached from the motor controller, the detector magnet has fallen off or the sensor has fallen out of alignment with the magnet. This can happen after changing a rear tire or performing other service on the rear wheel.

Solution:

1. Check that the speed sensor is in place and connected. When you turn on Electric Juggernaut, a red light on the end of the sensor should light. If not,
2. Refer to the section “[Wheel speed sensor alignment](#)” to realign the sensor. If following these instructions fails to correct the problem,
3. Contact Rungu Support to investigate other measures.

Problem: I am not getting the advertised range

Range depends on many factors – surface, tire pressure, power level, load, wind, incline, etc. Like a car, accelerating hard or spending more time in soft sand (you can do that with Rungu) will have a significant impact on the battery range of your Rungu. If you feel you are within the parameters of the performance specifications stated above, check the for the following problems.

Solution:

1. Check the tire pressure. The stated range uses tires at their highest pressure on dirt road.
2. Check that you're riding at optimal power and gear settings. The range is calculated at low speeds and usually in gears 5-7 riding at 7 or 10 mph.
3. Check the battery voltages – The battery should be 58-59 V with a full charge and be fully discharged at 42V. If your battery is not operating in this range, contact Rungu for detailed trouble shooting.
4. Check your brakes by spinning each wheel and listening for the rotor contacting the brake pads. If there is rubbing, align the brake calipers to eliminate the rubbing.
5. Contact Rungu Support if you have other questions.

Mechanical

Problem: I hear a clicking noise when I'm pedaling in every gear; gear changes take long or are difficult
The rear derailleur may be misaligned or bent, or the chain may be worn out.

Solution:

1. Adjust derailleur alignment. Use a stand or tethering to raise the rear wheel and while operating the pedals with your hands, use the shifter barrel adjustment to re-align your derailleur. If this fails to eliminate the clicking noise,
2. Check that the derailleur, derailleur hanger, or frame isn't bent or broken. Replace components as necessary. If the derailleur, hanger and frame are intact,
3. Replace the chain.
4. Contact Rungu Support if you have other questions.

Problem: I hear a loud click noise coming when I'm pedaling in a high gear

The cassette cog is worn out; replace cassette. Refer to the "[Understanding and changing the Power Level](#)" section above on how to avoid this problem after replacing the cassette.

Problem: I hear a rubbing or squealing noise from one, or both, of the front wheels when riding.

The rubbing noise may occur from the brake rotor rubbing against a rotor or the tire rubbing against the inside of the fork. A squealing noise indicates the brake pad is rubbing against the brake rotor.

Solution:

1. Check the wheel position in the fork. Loosen the quick release and on level ground apply pressure on the fork to make sure the wheel hub is engaged correctly in the dropouts. Retighten the quick release. If you notice that the tire is rubbing after the correction, take the wheel to be "trued" by bicycle technician. If the brake rotor continues to rub against the brake pad,
2. Re-align the brake caliper. Follow component directions on how to realign your brake caliper or have realignment performed by a qualified technician. If you cannot realign your brake caliper to eliminate the rotor rubbing against the brake pad,
3. The rotor is warped; replace it or have it replaced.
4. Contact Rungu Support if you have other questions.

Problem: I can't change into lower gears.

The derailleur may require adjustment or more seriously you have bent a cassette cog.

Solution:

1. Inspect the largest cassette cogs for damage. If a cog is bent it will prevent the chain from engaging with an adjacent cog. Replace the cassette if this is the case. Refer to the [“Understanding and changing the Power Level”](#) section above on how to avoid this problem after replacing the cassette. If the cassettes are undamaged,
2. Check Derailleur alignment. Use a stand or tethering to raise the rear wheel and while operating the pedals with your hands, try to shift into first gear. If the derailleur stops or has difficulty moving the chain into first gear, clean and lubricate the derailleur and refer to component directions to reset the high and low stops for the derailleur to ensure consistent gear changes. If the derailleur adjustments and cleaning fails to correct the problem,
3. Check that the derailleur, derailleur hanger, or frame isn't bent or broken. Replace components as necessary. If the derailleur, hanger and frame are intact,
4. Contact Rungu Support if you have other questions.

Getting more information

Thank you again for purchasing a Rungu Electric Juggernaut. For further questions, please consult the [Support Page](#) on the riderungu.com website or email support@riderungu.com.